

# **FARAONE**<sup>®</sup>

Industrie spa



## **STOCK PICKER**

***ELEVAH 40 MOVE PICKING***

***ELEVAH 40 B PICKING***

### **USE AND MAINTENANCE INSTRUCTIONS**

**Translation of the original instructions**



**SECTION 0. INTRODUCTION**

**TABLE OF CONTENTS**

SECTION 0.	INTRODUCTION.....	0-1
	TABLE OF CONTENTS .....	0-1
	PREMISE .....	0-2
	SYMBOLS AND TERMS.....	0-2
	TECHNICAL SUPPORT - WARRANTY.....	0-3
	NOTICES .....	0-3
SECTION 1.	SAFETY PRECAUTIONS .....	1-1
	GENERAL INFORMATION.....	1-1
	PRELIMINARY PROCEDURES .....	1-2
	OPERATION .....	1-3
SECTION 2.	GENERAL TECHNICAL DATA.....	2-1
	OVERALL DIMENSIONS AND CLEARANCES .....	2-2
	GENERAL TECHNICAL DATA .....	2-4
	BASIC CONSTRUCTION DATA.....	2-6
	REFERENCES TO STANDARDS .....	2-6
SECTION 3.	PREPARATION AND INSPECTION.....	3-1
	PERSONNEL TRAINING.....	3-1
	DAILY FUNCTIONAL TEST.....	3-2
	SAFETY WARNINGS FOR OPERATORS .....	3-3
SECTION 4.	CONTROLS, WARNING LIGHTS AND MACHINE OPERATION .....	4-1
	INTRODUCTION.....	4-1
	MACHINE OPERATION .....	4-1
	CHARGING THE BATTERY .....	4-1
	CONTROL CONSOLE IN THE CAGE (ELEVAH 40 MOVE PICKING) .....	4-4
	CONTROL CONSOLE IN THE CAGE (ELEVAH 40 B PICKING) .....	4-7
	MACHINE DISPLAY .....	4-8
	HANDLING THE MACHINE (ELEVAH 40 B PICKING).....	4-10
	ACCESS TO CAGE .....	4-11
	PARKING THE MACHINE .....	4-13
	TRANSPORT AND LIFTING PROCEDURES .....	4-13
	ELECTRIC LOADING PLATFORM.....	4-15
	REMOVABLE LOADING PLATFORM (OPTIONAL) .....	4-17
	CONTROLS AT THE BASE (OPTIONAL) .....	4-18
	ANTI-COLLISION RADAR SYSTEM (OPTIONAL).....	4-19
	ANTI-CRUSHING PROTECTION (OPTIONAL) .....	4-21
	MAXIMUM CAGE HEIGHT BLOCK (OPTIONAL) .....	4-21
	LITHIUM BATTERIES KIT (OPTIONAL).....	4-22
	MACHINE START-UP WITH CODE (OPTIONAL) .....	4-22
SECTION 5.	EMERGENCY PROCEDURES.....	5-1
	EMERGENCY OPERATION.....	5-1
	REPORTING THE INCIDENT.....	5-2
SECTION 6.	DAILY INSPECTION.....	6-1
SECTION 7.	ROUTINE MAINTENANCE.....	7-1
	SIX-MONTHLY MAINTENANCE (can be carried out by the operator).....	7-2
	YEARLY MAINTENANCE (must be carried out by adequately trained personnel) .....	7-2
	BIENNIAL MAINTENANCE (must be carried out by adequately trained personnel) .....	7-3
SECTION 8.	MAINTENANCE OPERATING INSTRUCTIONS.....	8-1
	CAGE SAFETY LOCK .....	8-1
	BATTERY MAINTENANCE .....	8-3
	HYDRAULIC OIL CHANGE .....	8-3
	REPLACING THE TRACTION WHEELS (ELEVAH 40 MOVE PICKING).....	8-4
	TRANSMISSION MOTOR (ELEVAH 40 MOVE PICKING) .....	8-4
	ELECTROMAGNETIC BRAKE (ELEVAH 40 MOVE PICKING).....	8-5
	CHANGING THE TORQUE REDUCER GREASE (ELEVAH 40 MOVE PICKING) .....	8-6
	REPLACING THE EXTENSION SLIDING PADS .....	8-6
SECTION 9.	ATTACHED DOCUMENTATION .....	9-1
	ATTACHMENT 1 – Layout for decal application.....	9-1
	ATTACHMENT 2 - Hydraulic diagram .....	9-3
	ATTACHMENT 3 – Electrical layout - ELEVAH 40 MOVE PICKING.....	9-4
	ATTACHMENT 4 – Electrical layout - ELEVAH 40 B PICKING .....	9-5
	ATTACHMENT 5 – Successful acceptance test certificate.....	9-6
	ATTACHMENT 6 – Declaration of conformity.....	9-7
SECTION 10.	MAINTENANCE LOGBOOK.....	10-1



ENGLISH

**PREMISE**

The purpose of this use and maintenance manual is to provide users with the essential information to carry out the steps intended for safe and correct machine operation, in accordance with the purposes for which it was manufactured.

All information in this manual must be read and understood before making any attempt to operate the machine.

THIS MANUAL IS VERY IMPORTANT DOCUMENTATION; ALWAYS KEEP IT NEAR THE MACHINE.

Due to continuous improvements to its products, Faraone Industrie Spa reserves the right to change technical data without any prior notice. For updated information, contact Faraone Industrie Spa.

**CAUTION**

**REMEMBER THAT NO EQUIPMENT IS SAFE IF THE OPERATOR DOES NOT COMPLY WITH THE SAFETY PRECAUTIONS**

**SYMBOLS AND TERMS****CAUTION**

The danger symbol draws attention to potential hazards that might cause injuries. To prevent any injuries or fatal accidents, comply with all safety instructions associated with the symbol.



Arrows are used in the pictures of the machine to indicate the specific points described in the text of the manual.

- **Stock picker:** A machine designed exclusively to carry, lift, stack or arrange loads on shelving, controlled by an operator stationed in the driver's position, which can be raised at the same time as the load handling device.
- **Cage:** A position from which the operator is able to control all driving positions and handle the load.
- **Loading platform:** Platform from where goods are loaded to be carried, lifted, stacked or arranged on shelving.
- **Extensible structure:** A structure connected to the frame that supports the cage and allows it to move to the required position.
- **Frame:** Machine Base. It may be pushed or self-propelled.

**TECHNICAL SUPPORT - WARRANTY**

The Customer must make sure to have the serial number of the machine and an accurate description of the problem or of the information to be provided before contacting the Manufacturer.

**The warranty period is 12 months from the date of the purchase invoice.**

Said warranty covers faulty components and the labour required for servicing, if this is carried out at the Manufacturer's premises (transport of the machine is borne by the purchaser).

**The warranty is valid provided all rules laid down for correct use of the machine are complied with.**

**The machine is designed and manufactured to last over the years provided it is always used as intended, and the maintenance work and inspections described herein are carried out. Faraone Industrie Spa deems it necessary to conduct an extensive analysis of all of the structural components every 10 (ten) years, to confirm their integrity.**

**NOTICES**

In compliance with legislation in force in the country where the machine is operating, the owner of the stock picker must find out whether a declaration of machine commissioning is required and for any periodical tests that are carried out thereafter.

**SECTION 1. SAFETY PRECAUTIONS****GENERAL INFORMATION**

This section illustrates the necessary precautions for correct and safe use of the machine and its maintenance. To assure correct use of the machine, it is essential to establish a daily routine procedure based on the instructions provided in the manual. Furthermore, to guarantee safe operation of the machine, a skilled person should establish a maintenance schedule based on the information provided in this manual, which must be strictly complied with.

The owner/user/operator/machine lessor company/lessee of the machine, shall not accept responsibility for its operation before having carefully read the manual and completed training and the operating procedures, guided by an experienced, skilled operator.

For further information relating to safety, training, inspection, maintenance, application and operation, contact Faraone Industrie Spa.

**CAUTION**

**FAILURE TO COMPLY WITH THE SAFETY PRECAUTIONS LISTED IN THE MANUAL MAY DAMAGE THE MACHINE AND PROPERTY AND CAUSE INJURIES OR FATAL ACCIDENTS.**

## PRELIMINARY PROCEDURES

### *Operator training and knowledge*

- Carefully read the manual before using the machine;



- Only use the machine after being fully trained by authorised personnel.
- The machine can only be used by authorised, skilled personnel.
- Read carefully and comply with all the CAUTION statements and operational instructions provided on the machine and in the manual.
- Use the machine for applications falling within those intended by Faraone Industrie Spa.
- All operational personnel must become familiar with the controls and emergency operation of the machine, as specified in the manual.
- Carefully read and comply with all company, local and government regulations in force, relating to machine operation.

### *Inspection of the workplace*

- Before using the machine, the operator must take the necessary precautions to prevent any hazard in the workplace.
- Do not operate the machine on lorries, trailers, railway carriages, boats in water, scaffolding or similar, unless Faraone Industrie Spa has approved the operation in writing.
- The machine can be switched on at temperatures between -15°C and 40°C. Contact Faraone Industrie for machine operation at temperatures not within the indicated range;
- The machine cannot be switched on in environments stated as ATEX, unless specifically indicated in the EC certificate of conformity delivered with the machine.

### *Machine inspection*

- Use the machine only after carrying out the inspections and functional checks. For further instructions, refer to *Section 3* of this manual;
- Operate the machine only after having carried out all assistance and/or maintenance specified in this manual;
- Make sure all safety devices work properly. Any changes to such devices constitute a breach of the safety regulations;
- Do not operate the machine if its signs or decals indicating the safety regulations or instructions are illegible or missing;
- Avoid building up debris on the floor of the machine. Prevent mud, oil, grease and other slippery substances from coming into contact with your shoes and the floor of the machine.



**CAUTION**

**ANY CHANGES OR ALTERATIONS TO THE MACHINE MAY ONLY BE CARRIED OUT WITH THE MANUFACTURER'S PRIOR WRITTEN AUTHORISATION.**

## OPERATION

### General information

- A self-propelled Stock picker is a machine designed solely to carry, lift, stack or arrange loads on shelving, controlled by an operator stationed in the driver's position, which can be raised at the same time as the load handling device.
- Do not expose the machine to atmospheric precipitations, water splashes and/or jets.
- Do not operate a faulty machine. Should a fault occur, switch off the machine;
- Do not move the control switches abruptly or levers from one position to the opposite one, going through the neutral position; always move the switch to the neutral position before moving it in the position of the next function. Operate the controls by exerting slow and even pressure;
- If persons are present in the cage, allow personnel to activate the machine from the ground, exclusively in the event of an emergency;
- Completely lower the extending structure and disconnect the power supply before leaving the machine unattended;
- *(In case of a battery powered machine)* Charge batteries in a well-ventilated area.

### Fall hazard



- Before using the machine, ensure all fixed and movable rails are secured in the correct position;
- Keep both feet firmly on the floor of the cage. Do not place ladders, boxes, steps, planks or similar items in the cage to increase the range of action;
- Do not use the extending structure to climb into the cage or climb down;
- Pay utmost attention when entering or exiting the cage. Make sure the extensible structure is lowered completely. When entering or leaving the cage, do so facing the machine. Always maintain "three contact points" with the machine, by making sure that both hands and one foot, or one hand and both feet, are continuously in contact with the machine when entering and exiting.

### Electrocution hazard



With regard to the safety distances from live parts of power lines and electrical systems that are not protected or not sufficiently protected to be complied with when carrying out non-electric jobs, at net clearance based on the type of job, the equipment used and the materials handled, as well as the sideways shifting of the conductors owing to the action of wind and lowering of heights due to heat conditions, refer to the Laws regarding safety in the workplaces of the country where the machine is operating.

For Italy, refer to Legislative Decree 81/08, annex IX "Values of rated operating voltages for electrical machines and systems".

### Overtuning hazard

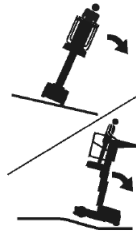

- Before driving the machine (*with self-propelled machine*), the user must check the work area surface. While driving, do not exceed the allowed transversal and longitudinal slopes;
- Do not lift the cage or drive the machine (*on a self-propelled machine*) on a slope or uneven or soft surface;
- Before driving the machine on floors, bridges, lorries and other surfaces, check their maximum capacity;
- Do not exceed the maximum capacity of the machine. Evenly distribute the loads on the loading platform as best as possible;
- Keep the machine chassis (*including stabilisers if present*) at a minimum distance of 0.5 m from holes, unevenness, descents, obstacles, debris, hidden holes and other potential dangers found at ground level;
- Do not attempt using the machine as a crane. Do not tie the machine to any adjacent structure;
- Do not increase the dimension of the cage or the loading platform with unauthorised extensions;
- If the extending structure or the cage get stuck so that one or more wheels are lifted from the ground, the operator must be made to get off the cage before attempting to release the machine. Use a crane, forklift or other adequate equipment to stabilise the machine and have personnel climb down from the cage;
- (*For machine not self-propelled*) Do not move the machine with the stabilisers engaged (*if any*) or with the extending structure raised. Before moving the machine, completely lower the extensible structure.

### Crushing and impact hazard



- When using the machine or lifting or lowering the cage, check the distances above, on the sides and below the cage;
- Do not lean over the cage rails when the machine is running;
- Always pay the utmost attention to prevent the operational controls and people in the cage from being hit or hindered by any obstacles;
- Ensure the operators of other machines at a height or at ground level are informed of the presence of the machine;
- Warn personnel not to work, stand or walk underneath the lifted cage;
- (*For machine with self-propeller*) When driving in areas where visibility is limited by obstacles, always have a person precede the vehicle to signal any dangers;
- (*For machine with self-propeller*) While driving, always keep non-operational personnel at a minimum distance of 2 m from the machine.
- (*For machine with self-propeller*) Adjust the driving speed according to the following conditions: ground surface, traffic, visibility, slope, location of personnel and other factors that can pose a risk of collision or injuries to personnel;



- (For machine with self-propeller) Take into account the braking distances regardless of the speed of the machine;
- (For self-propelled machine) Do not drive at high speed in reserved or tight areas or when reversing.

### ***Towing, lifting and carrying***

- Do not allow personnel to stand on the cage while towing, lifting and transporting;
- Only tow the machine in case of emergency, faults, a power-cut or to load/unload it;
- Before towing, lifting and transporting, make sure the cage is completely retracted and emptied;
- Do not pull or push a blocked or disabled machine.
- While lifting the machine with a forklift, only place the forks in the specific areas of the machine. Lift with lifting equipment of adequate capacity.

For information regarding lifting, refer to the relevant section in the manual.

**SECTION 2. GENERAL TECHNICAL DATA****CAUTION**

**SELF-PROPELLED STOCK PICKERS ELEVAH 40 MOVE PICKING / B PICKING ARE MACHINES DESIGNED EXCLUSIVELY TO CARRY, LIFT, STACK OR ARRANGE LOADS ON SHELVING, AND CONTROLLED BY AN OPERATOR STATIONED IN THE DRIVER'S SEAT, WHICH CAN BE RAISED AT THE SAME TIME AS THE LOAD HANDLING DEVICE. SELF-PROPELLED STOCK PICKERS ARE DESIGNED TO DRIVE IN CLOSED PREMISES ON PREPARED, SMOOTH AND HORIZONTAL SURFACES. THEY CAN ALSO BE USED OUTDOORS UNDER NO WIND CONDITIONS AND WITH NO ATMOSPHERIC PRECIPITATIONS. SELF-PROPELLED STOCK PICKERS MUST BE USED ONLY AS INTENDED. ANY OTHER USE IS CONSIDERED MISUSE.**

**OVERALL DIMENSIONS AND CLEARANCES**

**ELEVAH 40 MOVE PICKING**

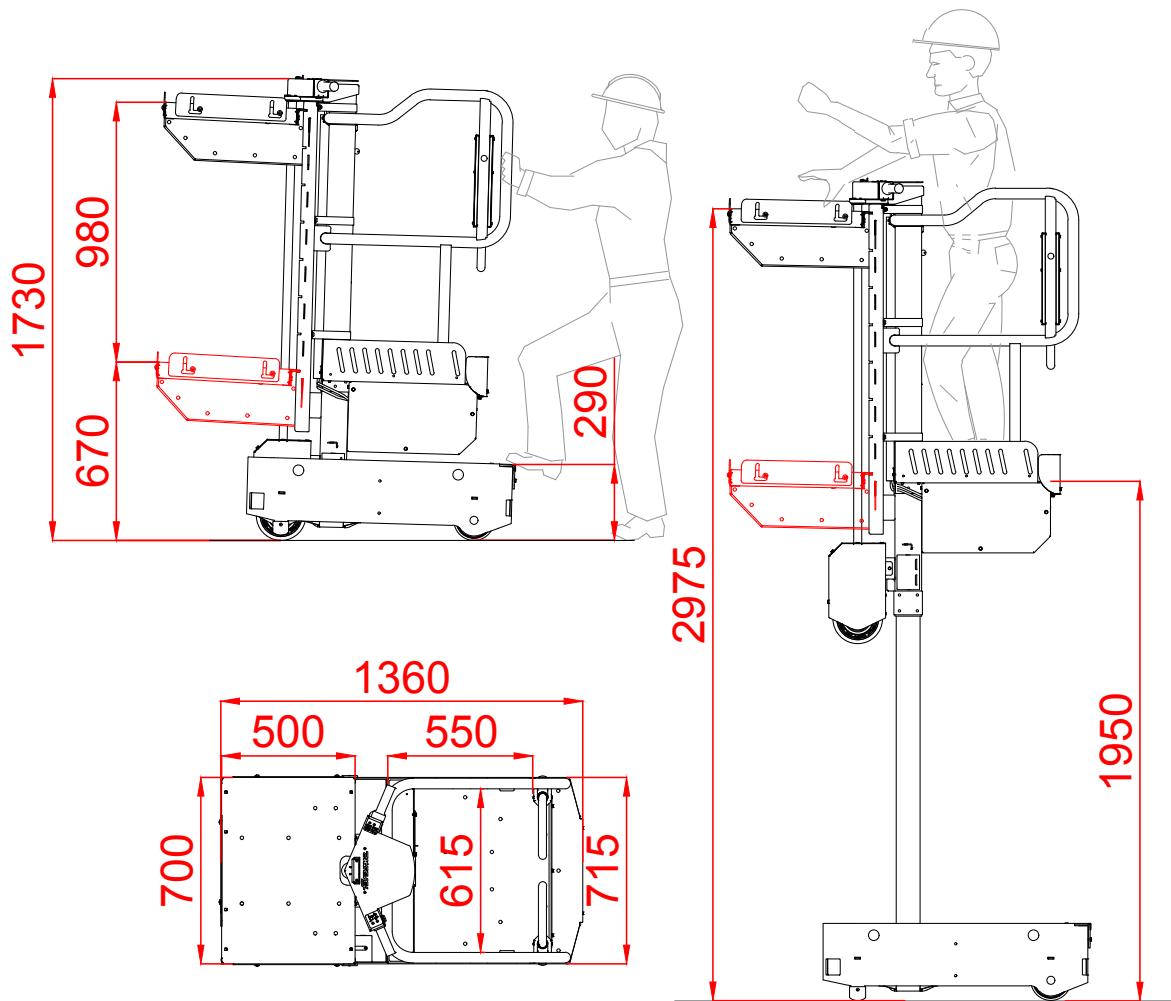

Measurements expressed in mm

**ELEVAH 40 B PICKING**

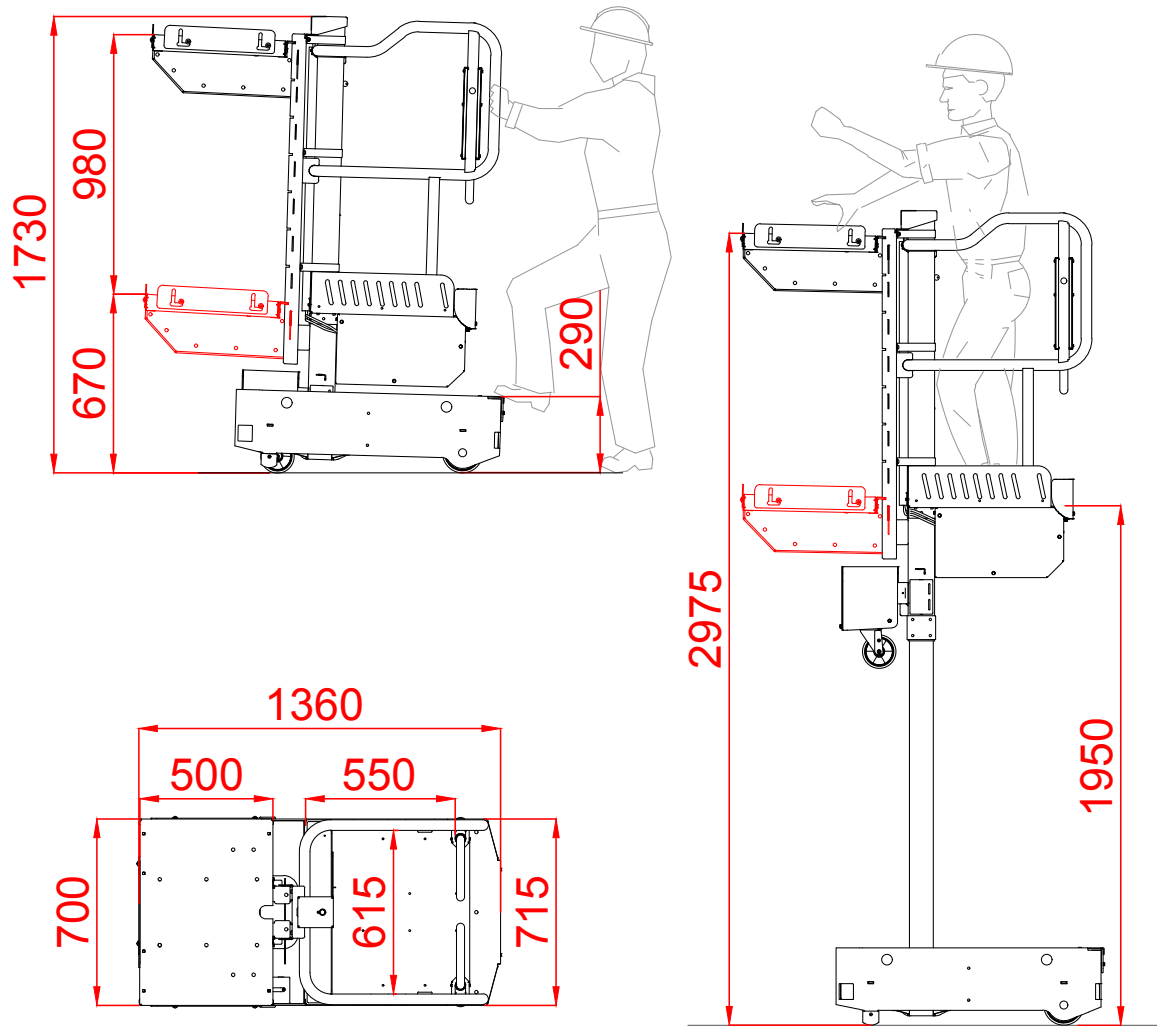

Measurements expressed in mm

**GENERAL TECHNICAL DATA**

<b>ELEVAH 40 MOVE PICKER TECHNICAL DATA</b>	<b>Value</b>
Weight of the machine (overall):	Refer to the CE plate affixed to the machine.
Maximum resting force on the ground (per wheel/stabiliser (*)):	Refer to the CE plate affixed to the machine.
Machine height (in transport position):	173 cm
Machine base overall dimensions:	1360 cm x 71 cm
Maximum hydraulic system pressure:	~ 60 bar
Required amount of oil for the hydraulic system:	~ 2.5 Litres
Power supply	2 x 12V 50Ah Lead acid batteries
Operators in the cage:	1
Maximum capacity of the cage + loading platform (manual or electric):	200 kg
Maximum capacity of the loading platform (manual or electric):	100 kg
Maximum cage height (from the ground to the floor of the cage):	1.95 m
Maximum cage height with self-propeller (from the ground to the floor of the cage):	N.A.
Maximum dimensions of the loading platform (manual or electric):	~ 50 cm x 70 cm
Internal dimensions of the cage:	~ 61 cm x 55 cm
Max shifting speed in transport position:	1.39 m/s
Maximum self-propelled movement speed at a height:	N.A.
Maximum cage rising speed:	0.15 m/s
Maximum cage descending speed:	0.15 m/s
Maximum longitudinal / transversal gradient in the transport position:	15%
Maximum longitudinal / transversal gradient in the raised position:	"Levelled" base

\* Maximum force per stabiliser considering that 70% of the weight of the machine plus the maximum load inside the cage are entirely distributed on one side only of the platform (entirely asymmetrical load)

<b>ELEVAH 40 B PICKING LIFTER TECHNICAL DATA</b>	<b>Value</b>
Weight of the machine (overall):	Refer to the CE plate affixed to the machine.
Maximum resting force on the ground (per wheel/stabiliser (*)):	Refer to the CE plate affixed to the machine.
Machine height (in transport position):	173 cm
Machine base overall dimensions:	1360 cm x 71 cm
Maximum hydraulic system pressure:	~ 60 bar
Required amount of oil for the hydraulic system:	~ 2.5 Litres
Power supply	2 x 12V 50Ah Lead acid batteries
Operators in the cage:	1
Maximum capacity of the cage + loading platform (manual or electric):	200 kg
Maximum capacity of the loading platform (manual or electric):	100 kg
Maximum cage height (from the ground to the floor of the cage):	1.95 m
Maximum cage height with self-propeller (from the ground to the floor of the cage):	N.A.
Maximum dimensions of the loading platform (manual or electric):	~ 50 cm x 70 cm
Internal dimensions of the cage:	~ 61 cm x 55 cm
Max shifting speed in transport position:	N.A.
Maximum self-propelled movement speed at a height:	N.A.
Maximum cage rising speed:	0.15 m/s
Maximum cage descending speed:	0.15 m/s
Maximum longitudinal / transversal gradient in the transport position:	15%
Maximum longitudinal / transversal gradient in the raised position:	"Levelled" base

\* Maximum force per stabiliser considering that 70% of the weight of the machine plus the maximum load inside the cage are entirely distributed on one side only of the platform (entirely asymmetrical load)

## BASIC CONSTRUCTION DATA

**MACHINE FRAME:** The frame of the machine (called base) is made completely of aluminium profiles with rectangular sections. All essential components for normal machine operation in stable conditions are installed on the frame.

**EXTENSIBLE STRUCTURE:** The extensible structure (column) consists of extruded galvanised iron profiles (called extensions) that slide on each other by means of nylon pads. A synchronised three-rod oil hydraulic cylinder is installed inside the column, powered by the hydraulic unit, to lift the structure.

**CAGE, OBJECTS HOLDER TRAY AND LOADING PLATFORM:** The cage, the objects holder tray and the loading platform are made entirely of galvanised iron profiles. The base platforms are built with 3 mm thick, non-slip, aluminium chequer plate.

**EXPOSURE TO VIBRATIONS:** The stock picker does not produce vibrations that pose a risk to the health of operators. The weighted acceleration that the whole body is exposed to is less than 0.5 m/s<sup>2</sup>

**SOUND EMISSIONS:** The A-weighted emission sound pressure level is below 70dB

## REFERENCES TO STANDARDS

The machine has been manufactured in accordance with the health and safety requirements of Machinery Directive 2006/42/EC and harmonised standard UNI EN 3691-1:2020.

In accordance with ISO 22915-1:2020, the Stock Picker sample was tested by the manufacturer using:

- Static stability tests

And it was subjected to the following additional tests:

- Overload test
- Operation tests

The results of the tests and the conformity of the machine are reported in the document in Annex 5.

**SECTION 3. PREPARATION AND INSPECTION****PERSONNEL TRAINING**

The stock picker is a machine designed to carry, lift, stack or arrange loads on shelving; therefore, it is essential for it to be used and serviced by trained personnel only.

The machine cannot be used by persons under the influence of alcohol or drugs or subject to epileptic seizures, dizziness or loss of physical control.

***Operator training***

Operator training must include the following:

- Use and limits of the machine's controls in emergency and operation controls and of the safety systems;
- Signs/stickers for controls, instructions and warnings on the machine;
- Regulations defined by the employer and government regulations;
- Sufficient knowledge of the mechanical operation of the machine to be able to recognise a fault;
- Safe methods for using the machine in the presence of overhead obstacles, other moving equipment and obstacles, hollows, holes and slopes;

***Training supervision***

Training must be carried out under the supervision of a skilled person, in an open space clear of obstacles. and must continue until the trainee can safely operate and use the machine.

***Operator responsibility***

The operator must be trained with regard to the responsibility and authority to switch off the machine in the event of a fault or any other unsafe condition relating to both the machine and the work area.

**NOTE:** *the owner shall provide skilled personnel for training upon delivery of the first units and even later, if required by the user or personnel.*



**DAILY FUNCTIONAL TEST**

At the end of the "DAILY INSPECTION" (section 6), carry out a functional test on all systems in an area free from overhead and ground obstacles.

**CAUTION**

**IF THE MACHINE IS NOT WORKING PROPERLY, SWITCH IT OFF IMMEDIATELY. ALERT MAINTENANCE PERSONNEL OF THE PROBLEM. DO NOT USE THE MACHINE UNTIL IT IS DEEMED SAFE FOR USE.**

Carry out a functional test as detailed below.

- 1. Check the manual descent valve for proper operation (EMERGENCY DESCENT).**
- 2. From the control console of the cage**
  - a. Make sure the control console is correctly assembled and securely fastened;
  - b. Lift and lower the cage checking that lifting and lowering are performed smoothly;
  - c. Activate all functions and check all limit, main and activation switches for proper operation:
    - Machine brakes (*on self-propelled machine*) – Drive the machine on a slope (not exceeding the nominal operational capacity on a slope) and stop it to ensure the brakes hold it;
  - d. Ensure all machine functions are disabled when operating (pressing) the emergency stop button;
  - e. (on a machine that is NOT self-propelled) Activate/deactivate the parking system by pressing the "BRAKE" and "DEAD MAN" buttons on the movement handles to ensure correct operation.
  - f. Make sure the electric loading platform is working correctly. Ensure it travels smoothly without any jolting, and that its up/down movement is not obstructed. Make sure all its parts are intact.

**SAFETY WARNINGS FOR OPERATORS**

Do not install and use the machine in the following cases:



**OUTDOORS AND IN WINDY CONDITIONS**  
**(DANGER OF LOSS OF STABILITY AND OVERTURNING)**



**CLOSE TO OVERHEAD OBSTACLES (power lines, overhangs, etc.)**  
**(ELECTROCUTION, IMPACT AND COLLISION HAZARD)**



**WITH EXCESSIVE LOADS COMPARED TO ALLOWED LIMITS**  
**(DANGER OF LOSS OF STABILITY AND OVERTURNING)**



**ON FLOORING WITH LOWER CAPACITY THAN THE WEIGHT OF THE MACHINE**  
**(DANGER OF LOSS OF STABILITY AND OVERTURNING)**



**IN ANY CIRCUMSTANCE NOT SPECIFICALLY INDICATED UNDER THE OPERATING  
CONDITIONS IN THIS MANUAL**  
**(GENERAL DANGER)**



**CAUTION**

**THE ELECTRICAL SYSTEM OF THE MACHINE IS NOT EXPLOSION-PROOF (NO ATEX):  
THEREFORE ITS USE IN AREAS SUBJECT TO ATEX RISK SHOULD BE STRICTLY  
AVOIDED.**

**When travelling:**

- ✓ Move the machine with caution avoiding sudden manoeuvres;
- ✓ **DO NOT CARRY PEOPLE on the base frame of the machine and in any position other than inside the cage;**
- ✓ Check the structural condition and cleanliness of the surfaces that the machine is used on (ensure the surface is suitable for the weight of the machine in work conditions).

**During ascent and descent:**

- ✓ Comply with the maximum capacity weights allowed in the cage;
- ✓ Ensure there are no overhead obstacles along the vertical trajectory;
- ✓ Do not cause dangerous vibrations and/or oscillations that would result in loss of machine stability and possible overturning.

**While loading the materials:**

- ✓ Make sure the weight of the material to be loaded does not exceed the maximum capacity of the loading platform;
- ✓ Set the load evenly on the loading platform so that the centre of gravity of the load always falls within the platform;
- ✓ Firmly secure the load before moving the loading platform, the cage or the machine.

**CAUTION**

**THE MACHINE DOES NOT HAVE AN AUTOMATIC BASE LEVELLING VERIFICATION SYSTEM. BEFORE PROCEEDING WITH THE ASCENT/DESCENT PHASE, VERIFY CORRECT INCLINATION OF THE BASE BY VISUALLY CHECKING THE SPIRIT LEVELS. THE SPIRIT LEVELS MUST BE CENTRAL IN RELATION TO THE INDICATOR, WITHIN THE TOLERANCE LIMITS.**

**CAUTION**

**CHECK THE POSITION OF THE SPIRIT LEVEL BEFORE LIFTING THE CAGE. WHEN USING THE MACHINE WITH THE BASE NOT COMPLETELY LEVEL, AVOID LIFTING THE CAGE TO PREVENT THE MACHINE FROM TIPPING OVER.**

**CAUTION**

**PROCEED DOWNWARD WITH CAUTION IF THE MACHINE MALFUNCTIONS DURING THE CAGE DESCENT AND THIS DOES NOT BLOCK WHEN JUST OFF THE GROUND. THIS TYPE OF MALFUNCTION DOES NOT INVOLVE ADDITIONAL RISKS TO THE OPERATOR, THEREFORE THE OPERATOR IS REQUIRED TO VERIFY THAT THE DESCENT TAKES PLACE CORRECTLY. IF NOT, PAY ATTENTION, SET THE MACHINE OUT OF SERVICE AND REPORT THE MALFUNCTION TO THE MANAGER.**

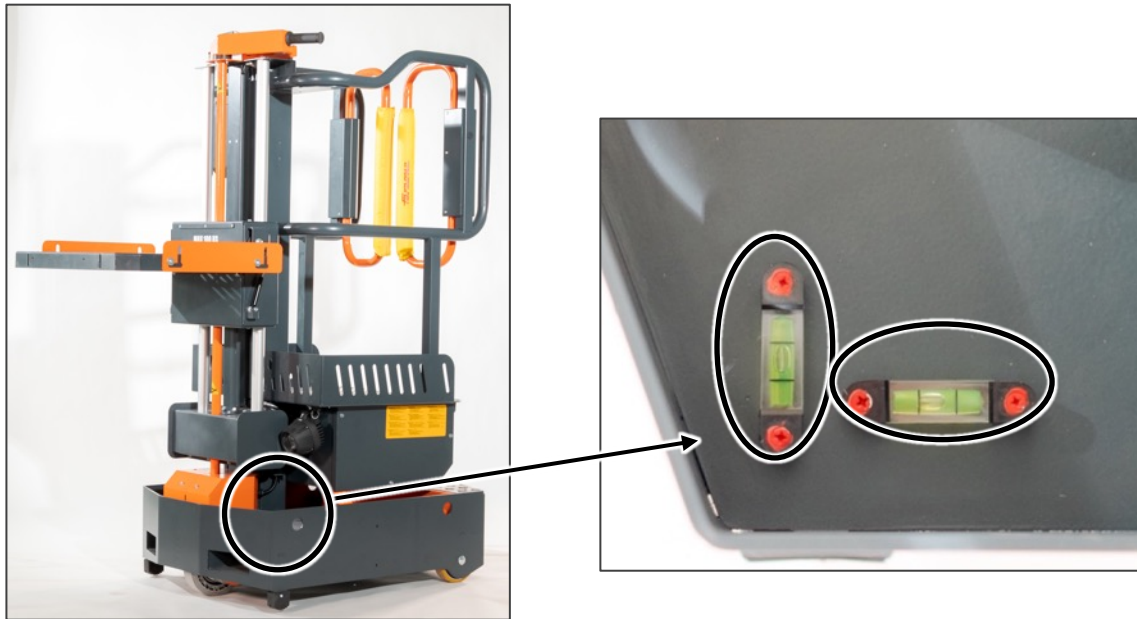











NOTE: The level bubbles are at the same position for both machine models



**CAUTION**

**IT IS STRICTLY FORBIDDEN TO TRY TO LEVEL THE MACHINE BY INSERTING ANY TYPE OF SHIM UNDER THE FRAME**

**Prohibition signs:**

-  Prohibition to overload the machine beyond the indicated limits
-  Prohibition to use the machine as an aerial platform to carry out work at a height
-  Prohibition to remove or tamper with the machine's stability devices (sensors, ballasts, etc.)
-  Prohibition to remove or tamper with the machine's safety and protection devices
-  Prohibition to climb on or off the cage in places other than the appropriate gate
-  Prohibition to increase outreach or work height of the machine using additional equipment (such as ladders)
-  Prohibition to cause oscillations on the machine so as not to destabilise it
-  Prohibition to install any additional device that increases the wind load on the machine (such as warning signs)
-  Prohibition to come into contact with live electrical conductors
-  Prohibition to climb on/off the cage when elevated
-  Prohibition to lift/lower the cage without operator on board

The Manufacturer recommends using the following personal protective equipment for safe use of the machine:



Protection of lower limbs

**NON-SLIP SHOES**



**CAUTION**

**THE USE OF ANY ADDITIONAL SPECIFIC PERSONAL PROTECTIVE EQUIPMENT MUST BE CHECKED BASED ON THE ASSESSMENT OF THE SPECIFIC RISKS, CARRIED OUT BY THE EMPLOYER**

The machine is equipped with an anchoring point for a fall arrest device to be used if it is required by the specific risk assessment for the work being carried out.

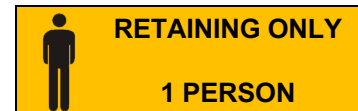
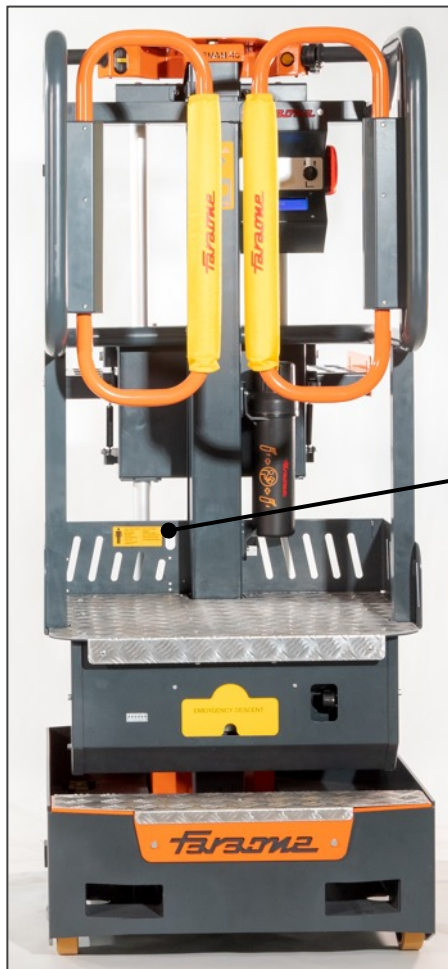

**SECTION 4. CONTROLS, WARNING LIGHTS AND MACHINE OPERATION****INTRODUCTION****CAUTION**

**THE MANUFACTURER DOES NOT HAVE ANY DIRECT CONTROL OVER MACHINE APPLICATION AND OPERATION. THE USER AND OPERATOR ARE REQUIRED TO COMPLY WITH THE CORRECT SAFETY PROCEDURES.**

Stock pickers model ELEVAH 40 MOVE PICKING / B PICKING are electric machines equipped with a cage assembled onto a lifting mechanism with aluminium uprights.

The self-propelled stock pickers are **DESIGNED TO CARRY, LIFT, STACK OR ARRANGE LOADS ON SHELVING AND CONTROLLED BY AN OPERATOR STATIONED IN THE DRIVER'S POSITION, WHICH CAN BE RAISED AT THE SAME TIME AS THE LOAD HANDLING DEVICE.**

The main control station is located in the cage. The operator can drive the machine and lift and lower the cage from the control console of the cage (when machine is self propelled in "MOVE PICKING" transport position) or can only lift and lower the cage (for the "B PICKING" manually pushed machine).

The vibrations generated by the machine do not constitute any danger for the operator who is inside the cage.

The continuous sound pressure level (A-weighted) in the cage is less than 70 db (A).

**MACHINE OPERATION*****Preliminary operations***

It is necessary for the following control conditions to be satisfied, before activating the machine from the controls in the cage.

- The battery voltage must be sufficient to operate the machine;
- The emergency stop switch with removable key, located on the control station in the cage must be on RESET.

**CHARGING THE BATTERY**

The machine is fitted with a battery charger with AC voltage input/DC voltage output. The battery charger automatically stops charging when the batteries are fully charged.

**CAUTION**

**KEEP SPARKS, NAKED FLAMES OR CIGARETTES AWAY FROM THE BATTERIES.  
PROVIDE ADEQUATE VENTILATION WHILE CHARGING.**

**NOTE:** when the battery charger is connected to an AC socket, the transmission function of the machine is disabled.

**Battery charging procedure**

1. Park the machine in a well-ventilated area, near an AC electric socket;
2. Turn the main switch to OFF and remove the key;
3. Connect the battery charger to a correctly installed and earthed socket according to regulations in force.

**Battery charge warning lights**

The battery charge warning lights are located on the left side of the machine's cage.

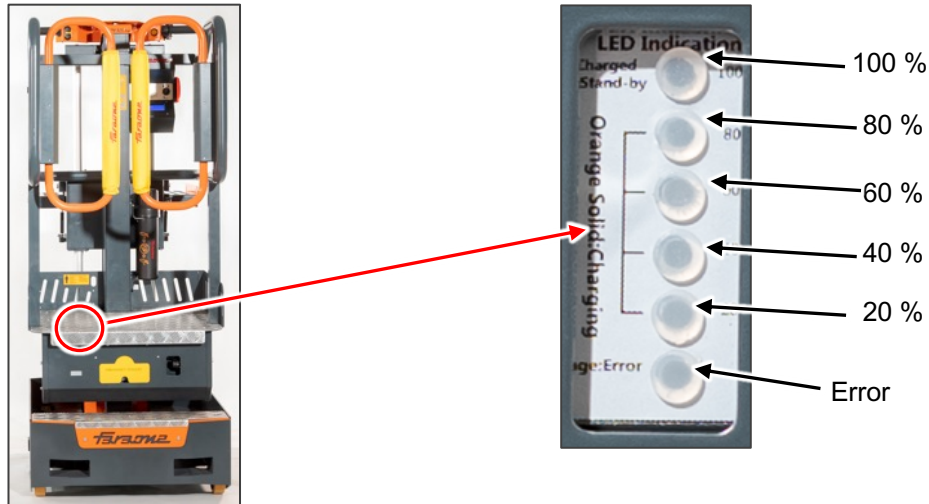

When charging the battery, the orange battery charge LEDs will light up from 20% up to 80%. Then the 100% green LED will light up to indicate that the charge is complete. If the machine is not disconnected from the mains, the green LED changes from steady to flashing, which indicates the standby status of the battery charger.

If, after connecting to the mains, neither the orange nor the green LEDs light up, there could be something wrong in the connection to the mains or the battery could be faulty; in which case, immediately report the problem to the manager.

If the orange error LED flashes, the following problems could occur:

Orange LED Blinking	Excessive temperature	Check the space between the charger and the nearby objects
	Over current	Remove the battery and check the charger
	Over voltage or low voltage	Remove the battery and ensure that the battery voltage is 12V or higher
	Short circuit	Check if the power socket is shorted

Perform the following operations carefully:

- ✓ Charging must be carried out in a well-ventilated area, where it is forbidden to smoke and use naked flames;
- ✓ It is recommended to avoid using any possible source of sparks near charging batteries;
- ✓ It is recommended to use anti-static clothing;
- ✓ Do not lift or tilt the batteries;
- ✓ Do not attempt to start the machine during the recharge.

**CAUTION**

**IT IS RECOMMENDED TO NEVER LET THE BATTERIES GO COMPLETELY FLAT.**

**CAUTION**

**WHEN THE MACHINE IS PUT OUT OF SERVICE FOR A LONG TIME, THE BATTERIES MUST BE FULLY AND EQUALLY CHARGED AT LEAST ONCE A WEEK AND STORED UNPLUGGED TO PREVENT THEM FROM GOING FLAT.**



**CONTROL CONSOLE IN THE CAGE (ELEVAH 40 MOVE PICKING)**

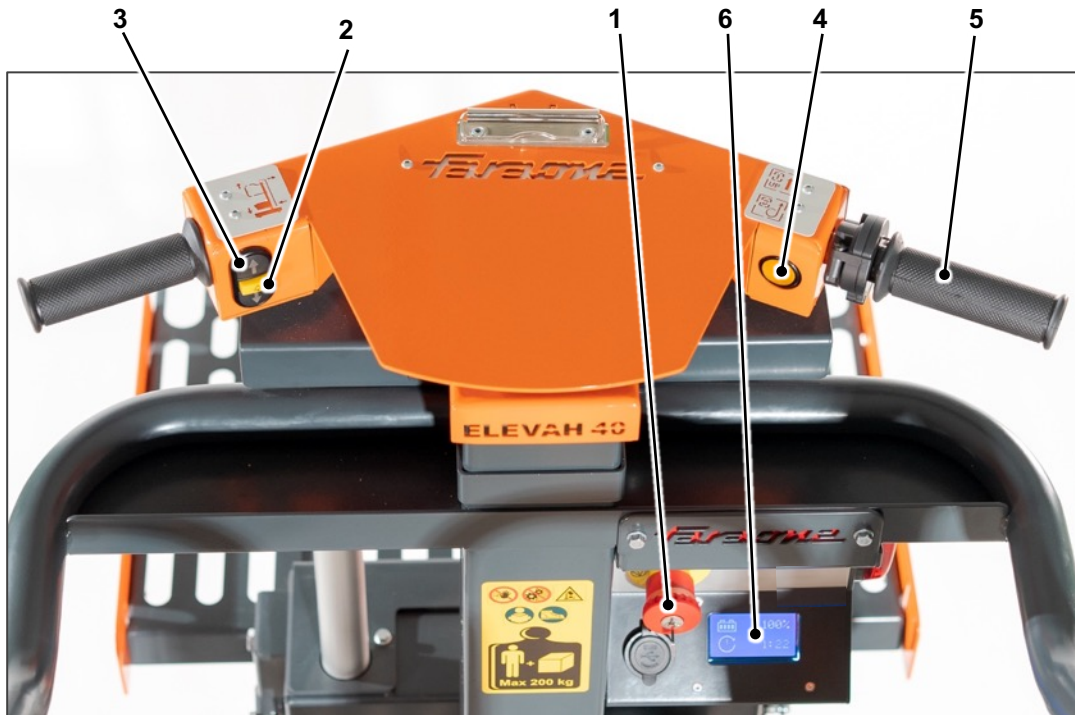

1. Emergency stop button with switch with removable key;
2. Audible device button;
3. Up/down - forward/backward control;
4. Cage run/lifting selector button;
5. Proportional control accelerator;
6. Error warning/battery charge/machine operation hour display.

**General information**

Before operating the machine from the cage control console, the following conditions of the controls must be met:

- The battery voltage must be sufficient to operate the machine.
- The emergency stop switch with removable key, located on the control station in the cage must be on RESET.

**Button to enable the cage run/lift**



0. Press (the button will remain inside the ring) to enable the movement of the cage (ascent/descent)
1. Press (the button will remain aligned with the ring) to enable the movement of the machine (front/back)

### Up/down - forward/backward control



- Cage UP direction or FORWARD drive of the machine
- Cage DOWN direction or BACKWARD drive of the machine



**NOTE:** After enabling the desired mode (machine drive/cage movement) and pressing the corresponding control for up/down or forward/backward movement, you must turn the proportional control accelerator in order to enable movement.



#### **CAUTION**

**BEFORE LIFTING THE CAGE, PAY ATTENTION TO WHAT IS STATED IN SECTION 3 "PREPARATION AND INSPECTION" WITH REGARD TO THE BASE LEVELLING CONTROL SYSTEM.**

### Proportional control accelerator

The accelerator actually enables movement after enabling the desired control mode (machine drive/cage movement) and pressing the corresponding control for up/down or forward/backward movement.



#### **CAUTION**

**THE ACCELERATOR IS EQUIPPED WITH PROPORTIONAL CONTROL. THE MORE THE KNOB IS TURNED, THE GREATER THE SPEED TO EXECUTE THE SELECTED MOVEMENT.**



#### **CAUTION**

**IT IS RECOMMENDED TO EXECUTE MOVEMENTS BY TURNING THE KNOB SLOWLY IN ORDER TO OBTAIN GRADUAL MACHINE ACCELERATION, ESPECIALLY WHEN USED BY INEXPERIENCED OPERATORS.**

**Emergency stop/switch-off button with removable key**

The emergency button located inside the control console of the cage is provided with a removable key to prevent the machine from being used by unauthorised personnel. Press the button and remove the key to disconnect the general power supply.

**POWER SUPPLY DISCONNECTION**

PUSH INWARDS to engage the emergency stop and remove the key to prevent unauthorised use.

**POWER SUPPLY CONNECTION**

Insert the key and TURN clockwise and RELEASE to reset the emergency stop.

**NOTE:** in order for the machine to operate, the emergency stop button on the cage must be on RESET.

**CAUTION**

**PREVENT UNAUTHORISED USE BY SWITCHING OFF THE MACHINE AND REMOVING THE KEY WHEN THE AERIAL PLATFORM IS NOT IN USE.**

**CONTROL CONSOLE IN THE CAGE (ELEVAH 40 B PICKING)**



1. Emergency stop button with switch with removable key;
2. Cage up/down control;
3. Error warning/battery charge/machine operation hour display.

**Emergency stop/switch-off button with removable key**

The emergency button located inside the control console of the cage is provided with a removable key to prevent the machine from being used by unauthorised personnel. Press the button and remove the key to disconnect the general power supply.



**POWER SUPPLY DISCONNECTION**

PUSH INWARDS to engage the emergency stop and remove the key to prevent unauthorised use.



**POWER SUPPLY CONNECTION**

Insert the key and TURN clockwise and RELEASE to reset the emergency stop.

**NOTE:** in order for the machine to operate, the emergency stop button on the cage must be on RESET.



**CAUTION**

**PREVENT UNAUTHORISED USE BY SWITCHING OFF THE MACHINE AND REMOVING THE KEY WHEN THE AERIAL PLATFORM IS NOT IN USE.**

**Ascent/descent control**



1. Turn the selector to the LEFT to LOWER the cage;
2. Turn the selector to the RIGHT to RAISE the cage.



**CAUTION**

**BEFORE LIFTING THE CAGE, PAY ATTENTION TO WHAT IS STATED IN SECTION 3 “PREPARATION AND INSPECTION” WITH REGARD TO THE BASE LEVELLING CONTROL SYSTEM.**

**MACHINE DISPLAY**

When the machine is powered, the machine display shows the state of the battery charge, the operating hours of the machine and any errors present.

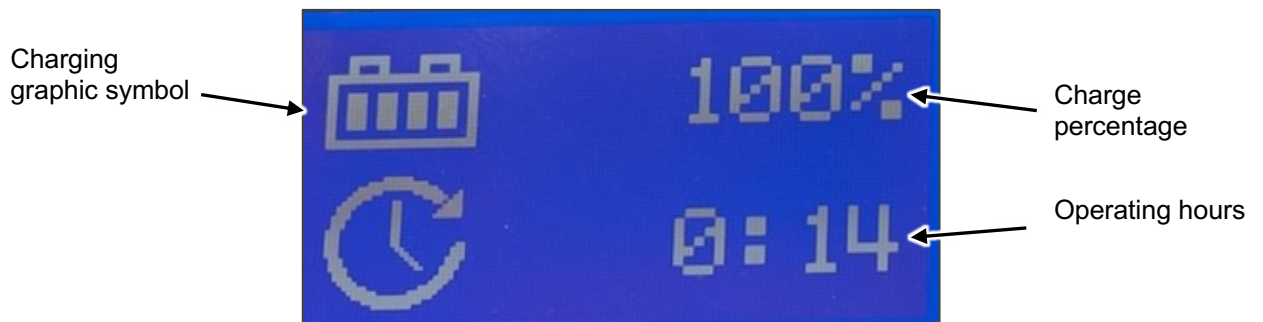

While using the machine, the battery charge will change from fully charged (*indicated with 4 lit bars and 100% charge*), to partially charged (*indicated with 2 lit bars and 50% charge*) to a flat battery (*indicated with no lit bars and 0% charge*).

**Machine errors**

As previously mentioned, the display also shows any errors in the machine. The following is an example of an indicated error:



<b>Error No.</b>	<b>Error description</b>	<b>Error cause</b>	<b>Solution</b>
ALARM 1	Drive current protection	Current peak above the drive limit	Restart the machine
ALARM 2	Motor current protection	Maximum set motor current exceeded	Restart the machine
ALARM 5	Accelerator error	Accelerator potentiometer disconnected or calibrated incorrectly	Contact assistance
ALARM 8	Maximum battery	Battery voltage over the maximum	Restart the machine
ALARM 9	Flat battery	Battery voltage over the minimum	Charge
ALARM 12	CANbus Error	No communication between the devices connected via CANbus	Contact assistance
ALARM 13	Controller error	Motor connected to the start, movement not allowed	Contact assistance
ALARM 14	Overheating	Board temperature over the limit	Restart the machine
ALARM 17	Control unit error	Internal checks	Contact assistance
ALARM 19	Current threshold exceeded	Current limit time exceeded.	Restart the machine
ALARM 49	Electric brake error	Error in the detection of the electric brake input when starting the machine	Contact Assistance
ALARM 84	Active accelerator	Acceleration potentiometer not idle when starting the machine	bring back to idle
ALARM 85	Active forward / back	Active forward / backward keys during machine start-up	Release control
ALARM 86	Internal error	Board internal voltage out of limits. Internal control.	Contact assistance
ALARM 88	Flat battery	Battery too flat to enable the ascent	Ascent not enabled, Recharge
ALARM 92	Active height limiter	Pressed top limit switch	
ALARM 93	Activated anti-crush	Enabled anti-crush	
ALARM 94	High Radar	Active top radar	
ALARM 95	Front Radar	Active front radar	
ALARM 96	Rear radar	Active rear radar	
ALARM 140	Loading platform error	Platform drive error due to current detection beyond the drive limit	Restart the machine
ALARM 144	Bed error	Disconnected platform motor	Disconnected motor
ALARM 145	Bed error	Active platform controls at start-up	Set the controls back to idle

**HANDLING THE MACHINE (ELEVATOR 40 B PICKING)**

Once descended completely, the cage remains slightly off the ground to ensure that the free wheel does not touch the ground, keeping the machine braked.

To move the machine, with the cage completely low, grasp the handles with your hands near the grasping point and simultaneously press the "BRAKE" and "DEAD MAN" buttons, located one on each handle.

With the buttons pressed simultaneously, the machine will fully lower the cage, allowing the free wheel to touch the ground, and disengage the brake so that it will be possible to move it to the workplace.

Release the buttons to bring the machine back to the braked condition with the cage slightly raised.

"DEAD MAN"

"BRAKE"



**CAUTION**

**WITH THE OPERATOR ON THE GROUND, THE MACHINE MUST BE HANDLED WITH THE POWER SUPPLY CONNECTED FOR THE PARKING SYSTEM TO FUNCTION CORRECTLY.**



**CAUTION**

**IF THE POWER SUPPLY IS DISCONNECTED WHILE THE "BRAKE" AND "DEAD MAN" BUTTONS ARE PRESSED SIMULTANEOUSLY, THE MACHINE WILL BLOCK AND NOT BE BRAKED.**

**TO RESTORE NORMAL MACHINE OPERATION, POWER IT AND PRESS THE "BRAKE" AND "DEAD MAN" BUTTONS SIMULTANEOUSLY.**



**CAUTION**

**PROCEED DOWNWARD WITH CAUTION IF THE MACHINE MALFUNCTIONS DURING THE CAGE DESCENT AND THIS DOES NOT BLOCK WHEN JUST OFF THE GROUND.**

**THIS TYPE OF MALFUNCTION DOES NOT INVOLVE ADDITIONAL RISKS TO THE OPERATOR, THEREFORE THE OPERATOR IS REQUIRED TO VERIFY THAT THE DESCENT TAKES PLACE CORRECTLY.**

**IF NOT, PAY ATTENTION, SET THE MACHINE OUT OF SERVICE AND REPORT THE MALFUNCTION TO THE MANAGER.**



**ACCESS TO CAGE**

To access the cage, the operator must push the moving parts of the entrance gate inwards; once inside, the gate will close by itself.

The machine will not enable any controls if the gate is not closed properly.

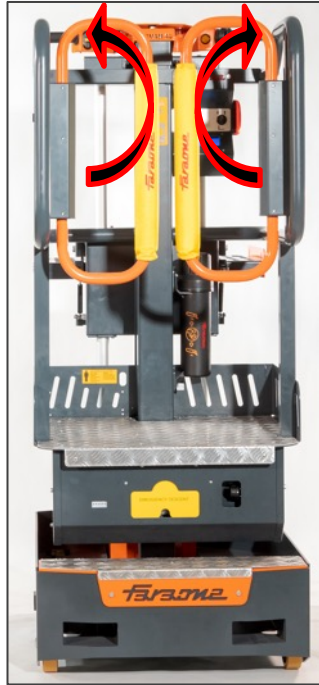

ELEVAH 40 MOVE PICKING



ELEVAH 40 B PICKING



**CAUTION**

**MAKE SURE THERE ARE NO OBSTACLES PREVENTING THE CAGE GATE FROM CLOSING PROPERLY**



**CAUTION**

**DO NOT OPEN THE GATE OF THE CAGE WHEN IT IS SUSPENDED SO AS TO AVOID THE RISK OF FALLING FROM A HEIGHT AND BLOCKING THE MACHINE FUNCTIONS**



**CAUTION**

**MAKE SURE YOUR HANDS DO NOT GET CAUGHT WHEN CLOSING THE GATE**



**CAUTION**

**DO NOT RAISE/LOWER THE CAGE IF THE MOBILE RAILING DOES NOT APPEAR TO CLOSE PROPERLY, AND HAVE IT REPAIRED (CONTACT THE MANUFACTURER, IF REQUIRED)**

**CAUTION**

**THE TOTAL NOMINAL LOAD IS OBTAINED BY ADDING THE LOAD IN THE CAGE + THE LOAD ON THE OBJECTS HOLDER TRAY + THE LOAD ON THE LOADING PLATFORM.**  
**THIS VALUE CANNOT EXCEED 200 KG IN ANY CASE**

## PARKING THE MACHINE

1. Drive / move the machine to a well-protected, ventilated area.
2. Make sure the cage is completely lowered, press the emergency stop/switch-off button with the removable key and take out the key.

**NOTE:** if necessary, charge the batteries in preparation for the following workday.



### **CAUTION**

**PREVENT UNAUTHORISED USE BY SWITCHING OFF THE MACHINE AND REMOVING THE KEY WHEN THE AERIAL PLATFORM IS NOT IN USE.**



### **CAUTION**

**IT IS RECOMMENDED TO PARK THE MACHINE PROTECTED FROM WEATHERING.**

## TRANSPORT AND LIFTING PROCEDURES

### General information

It is possible to transport the machine to the work premises using one of the following methods:

- By driving/pushing the machine and travelling the path on the base wheels, if the surface allows it;
- By moving it with a forklift (see the picture below – check the gross weight in the Operational Technical Data Table of the machine).
- Using the supplied forklift, supplied optionally, to quickly load onto the transport vehicle.



### **CAUTION**

**LOAD THE MACHINE, ONLY IN A VERTICAL POSITION, ONTO A HEAVY DUTY VEHICLE HAVING A USEFUL LOAD CAPACITY THAT WITHSTANDS THE TOTAL WEIGHT OF THE MACHINE (CHECK THE GROSS WEIGHT IN THE OPERATIONAL TECHNICAL DATA TABLE OF THE MACHINE)**



### **CAUTION**

**SECURE THE MACHINE SO THAT IT DOES NOT GET DAMAGED DURING TRANSPORT.**

**Handling with a forklift**

The machine can be lifted with a forklift truck. In this case, it must be held from the side part of the machine in order to position it in a stable way onto the forks (see following figure).



**CAUTION**

**ONLY LIFT THE MACHINE WITH THE CAGE COMPLETELY LOWERED.**

## ELECTRIC LOADING PLATFORM

The electrically-lifted loading platform is available as an optional extra instead of the removable loading platform.

The control to move the electric loading platform is found in the cage control console, as indicated below.



### Loading platform up/down control



- Turn the selector to the LEFT to LOWER the loading platform.
- Turn the selector to the RIGHT to RAISE the loading platform.

**NOTE:** The position of the selector with removable key shown in the picture may vary depending on the control console of the machine model where the system is installed.

### Electric loading platform closure

The optional loading platform in the ELEVAH 40 MOVE PICKING / B PICKING machines can be closed for easier movement of the machines in confined areas.

To close the loading platform proceed as follows:

1. Raise the loading platform up to the maximum height using the specific control;
2. Hold the loading platform with both hands and make it rotate upwards until it is blocked;
3. Use the specific control to lower the loading platform.



**CAUTION**

**MAKE SURE YOUR HANDS DO NOT GET TRAPPED WHEN THE LOADING PLATFORM IS CLOSING**

**REMOVABLE LOADING PLATFORM (OPTIONAL)**

The removable loading platform has a maximum capacity of 100 kg and can be manually secured in eight positions, as required.

**Installing the objects holder platform**

Insert the platform from the front of the machine into one of the possible positions, taking care to insert the pin (1) correctly in one of the grooves (2) available in the column.

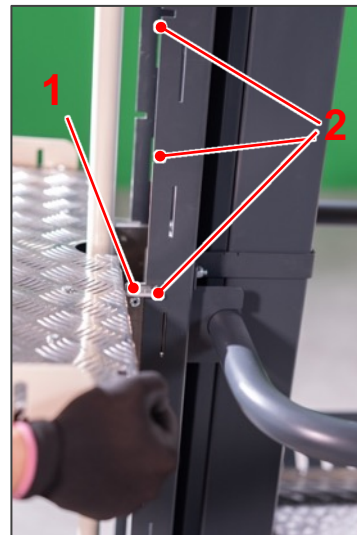
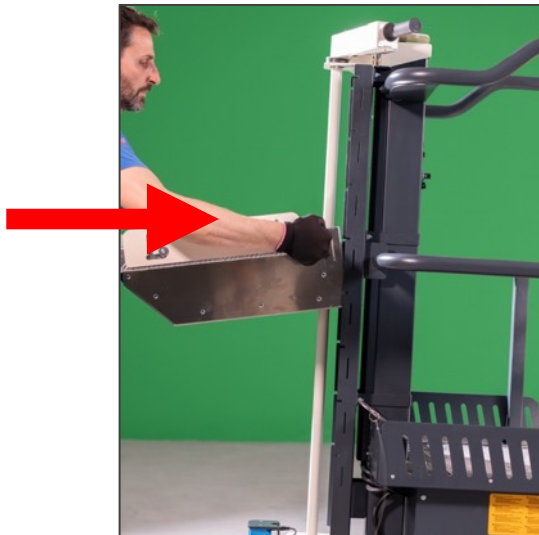

Fully insert the locking bracket into the relevant hole and hook the special safety spring catch in the hole at the other end of the bracket.



Remove the objects holder platform by carrying out the previous steps in inverse order and place it in a suitable place.



**CAUTION**

**USE THE LOADING PLATFORM ONLY AFTER CHECKING THAT IT IS BLOCKED CORRECTLY**

**CONTROLS AT THE BASE (OPTIONAL)**



1. Selector enabling base controls/controls in the cage;
2. Cage up/down control.

**General information**

Before operating the machine from the base control desk, the following conditions of the controls must be met:

- The battery voltage must be sufficient to operate the machine.
- Console in the cage – The emergency stop switch with removable key must be in the RESET position.
- Console at the base – The control enabling selector on the base/cage must be in the appropriate position.

**Controls selector on the base/in the cage**



**CONTROLS IN CAGE mode**

TURN the selector to the RIGHT to enable the controls in the CAGE.



**CONTROLS AT BASE mode**

TURN the selector to the LEFT to enable the controls at the BASE.

**Cage up/down control**



TURN the selector to the LEFT to LOWER the cage.  
TURN the selector to the RIGHT to RAISE the cage.



**CAUTION**

**DO NOT USE THE CONTROLS AT THE BASE WHEN THE OPERATOR IS IN THE CAGE**



## ANTI-COLLISION RADAR SYSTEM (OPTIONAL)

### Front anti-collision radar (E40 RADAR 1)

It is a distance detector installed on the machine base that prevents accidental impact with obstacles during frontal movements and stops the machine about 10 cm away from any obstacle.



**NOTE:** The image refers to a particular machine model, which may therefore vary depending on the machine model on which the system is installed.

### Rear anti-collision radar (E40 RADAR 1B)

It is a distance detector installed on the machine base that prevents accidental impact with obstacles during rear movements and stops the machine about 10 cm away from any obstacle.



**NOTE:** The image refers to a particular machine model, which may therefore vary depending on the machine model on which the system is installed.

### Top anti-collision radar (E40 RADAR 3)

It is a distance detector installed in the cage that prevents the operator from accidentally collide with overhead obstacles while the cage is lifted and stops the machine a safe distance away from any overhead obstacle.



**NOTE:** The image refers to a particular machine model, which may therefore vary depending on the machine model on which the system is installed.



**ANTI-COLLISION RADAR USE**

When the machine gets close to an obstacle during a movement, the radar system will lock all the features of the machine and stop it about 10 cm away from the obstacle.

The lock of the machine features caused by the presence of an obstacle along the pathway is signalled to the operator via the warning light integrated in the system release selector (1) in the control console lighting up.

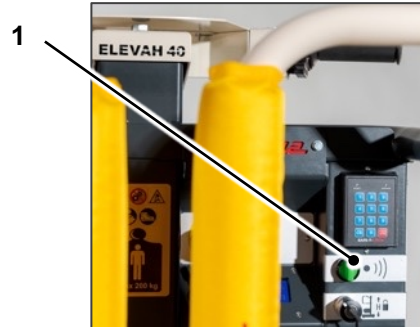

**NOTE:** The position of the release selector - warning light button shown in the picture refers to a particular model of machine, and therefore may vary depending on the control console of the aerial platform model where the radar system is installed.



Once the machine has been locked, proceed as follows to restore operation:

1. Disable the "Anti-collision Radar" system by turning the relevant selector (1) to the right;
2. Move 30 cm away from the obstacle;
3. Re-enable the "Anti-collision Radar" system by turning the relevant selector (1) to the left.

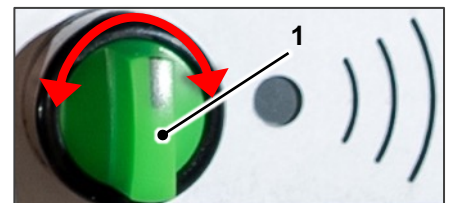

After that, normal machine operation will be restored.



**CAUTION**

**BY KEEPING THE "ANTI-COLLISION RADAR" SYSTEM DISABLED, YOU OBTAIN A SIGNIFICANT REDUCTION IN THE MOTION SPEED**

**ANTI-CRUSHING PROTECTION (OPTIONAL)**

There is a device under the cage made up of an aluminium panel that stops the cage from descending as soon as it is pressed.

If people or obstacles are inadvertently placed in the cage descent path, the device detects the obstacle and stops the cage with an acoustic sound.

After the cage descent has been stopped, in order to restart the machine, the operator must slightly lift the cage and move away from the obstacle, if necessary.



**NOTE:** The image refers to a particular machine model, which may therefore vary depending on the machine model on which the anti-crushing protection system is installed.

**MAXIMUM CAGE HEIGHT BLOCK (OPTIONAL)**

The maximum cage height block, when enabled, prevents the cage from exceeding a maximum height defined by the manufacturer (from the ground to the cage floor).

The maximum height block is enabled or disabled by turning a selector with removable key in the cage control console.

**Maximum Height Block Selector**



**Enabling the Block**

- TURN the selector to the RIGHT and remove the key.

**Disabling the Block**

- TURN the selector to the LEFT.

**NOTE:** The position of the selector with removable key shown in the picture may vary depending on the control console of the machine model where the system is installed.



**CAUTION**

**THE KEY SHOULD ALWAYS BE REMOVED WHEN THE MACHINE DOES NOT EXCEED THE MAXIMUM HEIGHT IN ORDER TO PREVENT UNAUTHORISED USE.**

**LITHIUM BATTERIES KIT (OPTIONAL)**

The Kit contains two 12.8 Volt 110 Ah lithium batteries and an increased 24 Volt 25 A battery charger. They double the operating power reserve with the same overall dimensions.

Longer lasting: approximately 1500 recharge cycles as opposed to 500 with AGM or acid lead batteries.

Do not use in cold environments, such as cold rooms.

**MACHINE START-UP WITH CODE (OPTIONAL)**

The machine start-up system with code enables the machine to be used only by trained operators and is useful in crowded environments as it prevents the machine from being started by unauthorised people.

**CAUTION**

**THE KEYPAD IS A SEALED UNIT.  
REMOVING OR TAMPERING WITH THE EPOXY ENCLOSURE WILL VOID THE WARRANTY.**



**NOTE:** *The position of the keypad for entering the start-up code shown in the picture varies depending on the machine where it is installed.*

The code switching unit offers a high level of security to prevent unauthorised use of the equipment. To set, program, use and retrieve data from the unit, there are two operating menus: supervisor and user.

**The Supervisor Menu gives access to the following functions:**

- Changing Supervisor PIN;
- Add / eliminate users;
- Last User;
- Maintenance cycle menu.

**The User Menu gives access to the vehicle along with the option of carrying out the following functions:**

- Changing user PIN;
- Using the machine.

**SUPERVISOR MENU****Access to the Supervisor Menu:**

1. Press "00" to open the Supervisor Menu;
2. Enter the Supervisor's code (4-8 digits);
3. Press "Power/Enter"
  - The high-pitched beep accompanied by green and red LEDs indicate that the Supervisor Menu has been accessed correctly

**NOTE:** *Incorrect code entry is indicated by the red LED and a low-pitched acoustic sound.*

**NOTE 1:** *The default Supervisor PIN is factory set at (00) 1234. It is advisable to change this code following the instructions below in "Function 1".*

**NOTE 2:** *If the Supervisor PIN is lost or forgotten, the unit can be reset to the default PIN (00) 1234 by simultaneously pressing 1, 3, 7 and 9 until the reset beep sounds, followed by the green and red LEDs flashing 4 times (after about 5 seconds). Press CE to confirm.*

**NOTE 3:** *Key activation is always confirmed when any key is pressed with a beep and the green LED flashing.*

Once the Supervisor Menu is opened (as described above), the four permitted functions are now available:

1. Changing the Supervisor PIN
2. Add / Eliminate users
3. Last User
4. Maintenance menu

**Function 1 - Changing Supervisor PIN:**

1. From the Supervisor Menu, press "1" and then press the "Power/Enter" key to access the changing Supervisor PIN function;
  - The high-pitched beep and single flashing of the red LED indicate that function 1 has been accessed correctly.
2. Enter a 4 - 8 digit PIN and then press the "Power/Enter" key;
  - The green LED will flash as many times as the number of digits entered (4-digit PIN = 4 flashes).
3. To confirm, enter the 4 - 8 digit PIN entered before and then press the "Power/Enter" key;
  - The high-pitched beep accompanied by the green and red LEDs lighting up indicate that the new PIN has been accepted.
4. Press the "CE" key to save the new Supervisor PIN.
  - The high-pitched beep accompanied by the green and red LEDs lighting up indicate that the new PIN has been saved, you are then taken back to the Supervisor Menu.
5. Choose another function from the Supervisor Menu or press "CE" to exit the Supervisor Menu.

## **Function 2 - Add / Eliminate users**

1. From the Supervisor Menu, press “2” and then press the “Power/Enter” key to access the Add / Eliminate user function.
  - The high-pitched beep and two flashes of the red LED indicate that function 2 has been accessed correctly.
2. Press the 2-digit user ID (01-99) to be enabled and then press the “Power/Enter” key.
  - The unit will respond with the green LED and high-pitched beep to indicate that the user ID is available or the red LED and low-pitched beep to indicate that the user ID is already assigned.
3. Press the “Power/Enter” key again to edit the user ID status. One of the two following results will occur:
  - The green LED / high-pitched beep ⇒ indicates that the user ID is enabled.
  - The red LED / high-pitched beep ⇒ indicates that the user ID is disabled.

**NOTE:** *During the above procedure the status of the user ID can be switched from disabled to enabled mode by pressing the “Power/Enter” key again.*

4. Press the CE key to save the assigned user;
  - The high-pitched beep accompanied by the green and red LEDs indicate that the assigned users have been changed correctly.
5. Repeat the process to add / eliminate other users or press the CE key to exit the Supervisor Menu.

## **Function 3 - Last User**

1. From the Supervisor Menu, press “3” and then press the “Power/Enter” key to access the Last User function;
  - The high-pitched beep and three flashes of the red LED indicate that function 3 has been accessed correctly.
2. Press the “Power/Enter” key to start reading the user code;

**NOTE:** the code is given as a combination of flashes from the indicator LEDs. The green LED indicates the tens digit and the red LED indicates the units digits.

(Example: 8 flashes of the green LED followed by 3 flashes of the red LED indicate that user n°83 was the last person to use the machine.)

3. To display the Last User again, press the “Power/Enter” key again;
4. Press CE to exit function 3;
  - The high-pitched beep accompanied by the green and red LEDs indicates exit from function 3.
5. Choose another function from the Supervisor Menu or press “CE” to exit the Supervisor Menu.



### **Function 4 - Maintenance menu**

1. From the Supervisor Menu, press “4” and then press the “Power/Enter” key to access the maintenance function;
  - The high-pitched beep and four flashes of the red LED indicate that function 4 has been accessed correctly.
2. Press the “Power/Enter” key to enable the maintenance alarm;
  - The high-pitched beep and the green LED lighting up indicate that the maintenance alarm is enabled. The alarm will be set to sound after 250 hours of machine operation.
3. To disable the alarm: press the “Power/Enter” key again;
  - The high-pitched beep and the red LED lighting up indicate that the maintenance alarm is disabled.
4. Press CE to exit function 4.
  - The high-pitched beep accompanied by the green and red LEDs indicates exit from function 4.
6. Choose another function from the Supervisor Menu or press “CE” to exit the Supervisor Menu.

To reset the maintenance alarm after 250 hours, disable and re-enable the alarm function as described above.

### **Exiting the Supervisor Menu**

After all the supervisor operations have been carried out on the unit, press the CE key to exit the Supervisor Menu.

Disconnecting the power supply to the unit will take the unit out of the Supervisor Menu.

**NOTE:** Leaving the unit idle for one minute automatically exits the Supervisor Menu.

## **USER MENU**

### **Normal machine use**

1. Enter the two-digit user ID (created by the Supervisor) followed by the personal PIN;

**NOTE:** the default user PIN is 1 2 3 4 (this PIN can be changed as described below).

2. Press the “Power/Enter” key.
  - The high-pitched beep accompanied by the green LED indicates that the unit is on and the machine is ready for use.

**NOTE:** While the lock is on, the green LED flashes occasionally, indicating that the electronic lock is enabled.

### **Changing the user PIN**

1. Enter the two-digit user ID followed by the personal or default PIN;
2. Press the “Power/Enter” key
  - The high-pitched beep and green LED indicate that the unit is on.
3. Press “1” and then press the “Power/Enter” key (within one minute of enabling the user);
  - The red LED will flash once.
4. Enter the new 4-8 digit PIN and then press the “Power/Enter” key;
  - The green LED will flash once.
5. To confirm, enter the new PIN again and then press the “Power/Enter” key;
  - The high-pitched beep accompanied by the green and red LEDs indicate that the new PIN has been accepted.
6. The new PIN can now be used to access the vehicle.

### **Locking the machine**

The operator can lock the machine as follows:

1. Press the “Power/Enter” key;
2. Disconnect power to the machine.

**SECTION 5. EMERGENCY PROCEDURES**

This section shows the operations to be carried out in the event of an emergency during machine operation.

**EMERGENCY OPERATION****Operator unable to control the machine**

CONDITIONS IN WHICH THE OPERATOR IS IMMOBILISED, TRAPPED OR UNABLE TO OPERATE OR CONTROL THE MACHINE.

- The other personnel must only operate the machine from the emergency controls on the ground in case of absolute need.
- The machine controls must only be used by qualified personnel. DISCONTINUE MACHINE ACTIVITY IF THE CONTROLS ARE NOT WORKING CORRECTLY.
- In case of incorrect operation of the controls or power outage, the emergency stop must be pressed and a qualified operator must carry out the EMERGENCY DESCENT procedure from the ground.

Proceed as follows:

1. Press the emergency button to disconnect the power supply;
2. ATTENTION: make sure there is no one within the working range of the machine;
3. Lift the yellow protective shield at the base of the cage with your finger (as shown in the picture) and gradually loosen the knurled knob inside it so as to lower the operator platform;

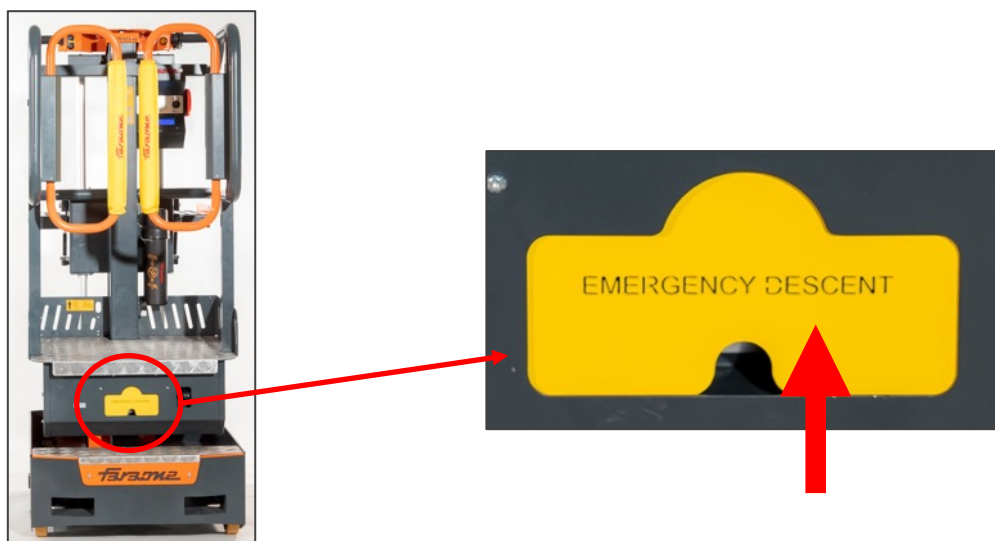

4. ATTENTION: continuously monitor the entire descent of the operator platform;
5. Once descent is completed, tighten the knob again;
6. Reset the emergency button to enable the machine's power supply.



**CAUTION**

**THE OPERATIVE STAGES OF THE EMERGENCY DESCENT PROCEDURE ARE SET OUT ON AN APPROPRIATE DECAL NEAR THE EMERGENCY DESCENT CONTROL.**

### ***Cage blocked in overhead position***

If the cage blocks or jams in overhead equipment or structures, transfer the person present in the cage to a safe place before freeing the machine.

Recovery equipment can be used to allow the occupant to climb down from the cage. A crane or forklift may be used to stabilise machine movement.

## **REPORTING THE INCIDENT**

Faraone Industrie Spa must be immediately informed of any incidents involving a Faraone product. Contact the factory by telephone and provide all the necessary details, even if no injuries or evident damage to property are involved.



### **CAUTION**

**AFTER AN ACCIDENT, INSPECT THE ENTIRE MACHINE AND CHECK ALL FUNCTIONS. DO NOT LIFT THE CAGE UNTIL YOU ARE CERTAIN THAT ALL DAMAGE HAS BEEN REPAIRED, AS REQUIRED, AND THAT ALL CONTROLS ARE WORKING PROPERLY.**



**SECTION 6. DAILY INSPECTION**

Start the full inspection from point (a), as set out in the following list. Proceed around the machine checking all listed conditions in sequence.

**CAUTION**

**TO PREVENT ANY INJURIES, ENSURE THAT THE MACHINE POWER SUPPLY IS SWITCHED OFF DURING THE "FULL INSPECTION".**

**DO NOT USE THE MACHINE BEFORE REPAIRING ALL FAULTS.**

**DO NOT FAIL TO CARRY OUT A VISUAL INSPECTION OF THE LOWER PART OF THE BASE FRAME. ENSURE THE AREA IS CLEAR OF OBJECTS OR DEBRIS THAT MIGHT CAUSE SERIOUS DAMAGE TO THE MACHINE.**

**NOTE FOR INSPECTION:** *besides complying with the above criteria, ensure for each component that all parts are in place, securely fixed and not loose, and that there is no visible damage, leaks or signs of excessive wear.*

- a) **Drive wheels/idler wheels and swivel wheels:** Check there is no debris attached to the wheels or around them;
- b) **Base frame:** Ensure there are no loose wires or cables hanging underneath the base, check for any dents, breaks or cracks on the profiles;
- c) **Manual descent control valve:** see note pertaining to functional check;
- d) **Motor/pump/tank unit:** No conspicuous hydraulic leak, hydraulic oil filling level at the "full" line;
- e) **Batteries:** It is necessary to check for any corrosion and tightening of the terminals and any topping up of acid inside the battery (if lead / acid type).  
If necessary, then, charge the battery;
- f) **Cage unit and entrance doors:** Correct blocking of the cage and entrance doors operating correctly;
- g) **Cage control console:** Controls secured, legible signs, emergency stop switch in the reset position for operation and legible control signs;
- h) **Extensible structure unit:** Structure profiles, sliding inserts that can slide freely;
- i) **Level bubbles:** Check the integrity of the spirit levels on the base frame;
- j) **Loading platform:** Check for dents, breaks or cracks on the structure, and check that the moving parts slide properly;
- k) **Parking system (ELEVAH 40 B PICKING):** Check and verify that the parking system functions correctly.

**CAUTION**

**DO NOT USE THE MACHINE BEFORE REPAIRING ALL DISCOVERED FAULTS / MALFUNCTIONS**

**SECTION 7. ROUTINE MAINTENANCE****CAUTION**

**SIX-MONTHLY MAINTENANCE CAN BE CARRIED OUT DIRECTLY BY THE MACHINE OPERATOR.**

**CAUTION**

**YEARLY AND BIENNIAL MAINTENANCE MUST BE CARRIED OUT BY COMPANY PERSONNEL WITH EXPERIENCE IN MAINTENANCE WORK AND ADEQUATELY TRAINED WITH REGARD TO SAFETY STANDARDS IN FORCE.**

**CAUTION**

**IT IS RECOMMENDED TO ONLY USE SPARE PARTS APPROVED BY THE MANUFACTURER.**

**CAUTION**

**CONTACT THE MANUFACTURER IF IN DOUBT WITH REGARD TO THE FREQUENCY AND METHOD OF ROUTINE AND/OR EXTRAORDINARY MAINTENANCE ACTIVITIES. DO NOT TAKE INITIATIVES IF UNSURE OF WHAT YOU ARE DOING.**

**CAUTION**

**TO PERFORM MAINTENANCE AND/OR CLEANING OPERATIONS ON THE MACHINE THAT REQUIRE KEEPING THE EXTENDIBLE STRUCTURE PARTLY EXTENDED, FOLLOW THE INSTRUCTIONS IN "CAGE SAFETY LOCK" (SECTION 8).**

**CAUTION**

**THE RECOMMENDED FREQUENCY OF LUBRICATION AND WEAR CHECKS IS BASED ON NORMAL USE. IF THE MACHINE IS USED FOR HEAVY DUTY WORK, SUCH AS A HIGH NUMBER OF CYCLES, UNFAVOURABLE POSITION, CORROSIVE/DIRTY ENVIRONMENT, ETC., THE USER MUST INCREASE THE FREQUENCY OF THE CHECKS ACCORDINGLY.**

**SIX-MONTHLY MAINTENANCE** (*can be carried out by the operator*)

- **Check the emergency descent valve for proper operation.**  
Lift the cage to a height and execute an “emergency descent”, as indicated in the appropriate section of this manual.
- **Hydraulic Oil**  
Check the hydraulic oil level and top up, as required.  
Refer to the specifications in the appropriate paragraph for information regarding hydraulic oil checks and top-up;
- **Check the hydraulic oil piping connections and make sure there are no leaks;**
- **Check the cage and entrance doors**  
Correct blocking of the cage and entrance doors operating correctly.
- **Check the correct operation and integrity of the controls in the cage**  
Controls functioning correctly, firmly fastened, control warnings and marks legible.

**YEARLY MAINTENANCE** (*must be carried out by adequately trained personnel*)

- **Checking the sliding pads of the extensible column**  
Each part of the lifting column, called extension, slides over the other by means of nylon pads. With regular machine use, these could be worn and cause a gradual direct rubbing on the extensions, thereby compromising the efficiency of the extensible structure.  
Check if the extensions rub against each other; if so, the machine must be stopped and the pads replaced. For this, it is advisable to contact Faraone S.p.A. or an authorised maintenance centre. Refer to the “REPLACING THE EXTENSION SLIDING PADS” chapter for more information.
- **Transmission motor (ELEVAH 40 MOVE PICKING)**  
Check the brushes for wear and replace them if required, and check the manifold.  
Refer to the instructions in the relative paragraph for information regarding checking and replacing the brushes;
- **Check there is no clearance, mechanical parts not correctly secured and/or bent and no damaged welds on parts/components;**
- **Check the integrity of the structural profiles;**
- **Check the wheels for wear**  
Check there is no debris on the wheels or around them. Check the tread for wear or damage. The wheels must be replaced if the edges are worn or the profiles deformed. If the wheels have significant damage on the tread or sides, immediately assess the severity of the damage before operating the machine again.  
It is advisable to replace the wheel before the thickness of the tread becomes less than 5 mm.

**BIENNIAL MAINTENANCE** (*must be carried out by adequately trained personnel*)

- **Hydraulic Oil**  
Replace the hydraulic oil in the tank.  
Refer to the specifications described in the appropriate paragraph for hydraulic oil change.
- **Torque Reducer (ELEVAH 40 MOVE PICKING)**  
Inspect the reducer and change the oil.  
Refer to the instructions in the appropriate paragraph for information on changing the oil of the reducer.
- **Transmission motor (ELEVAH 40 MOVE PICKING)**  
Carry out a general overhaul of the drive wheels.

**SECTION 8. MAINTENANCE OPERATING INSTRUCTIONS**

**CAGE SAFETY LOCK**

To perform maintenance that requires keeping the cage lifted up, follow these instructions for positioning the safety locking pin supplied with the machine.

The locking pin is found near the level bubbles in the base of the machine and is secured to the machine with a knob.

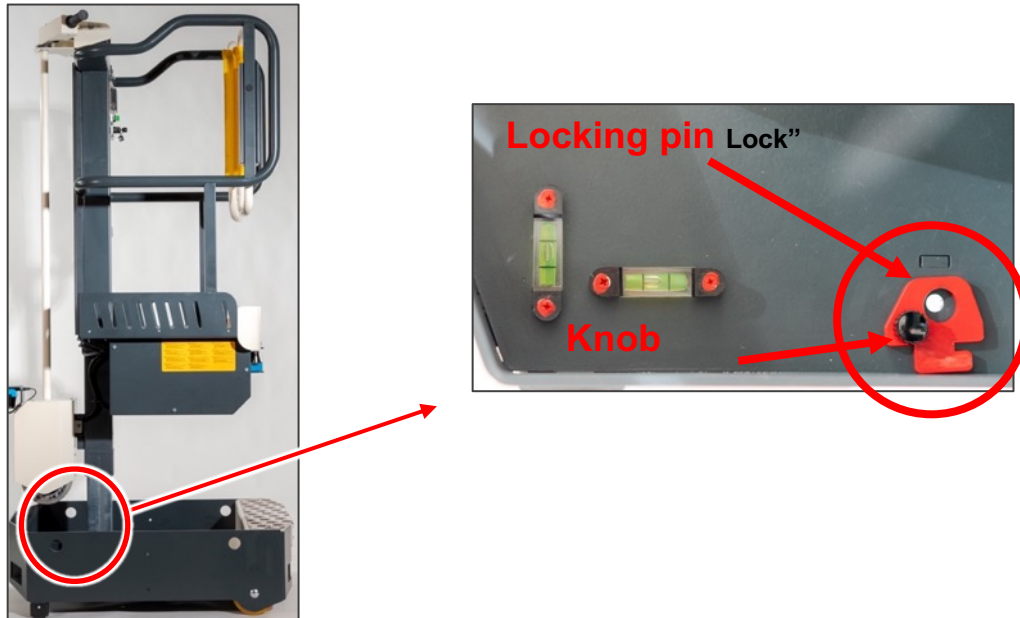

**CAUTION**

**TWO OPERATORS ARE REQUIRED TO CARRY OUT THIS PROCEDURE SAFELY**

1. Remove the locking pin from inside the machine base by unscrewing the knob;
2. Lift the basket until the slot for inserting the locking pin appears in the column, as shown in the picture, and safely descend from it using a ladder or another suitable support;

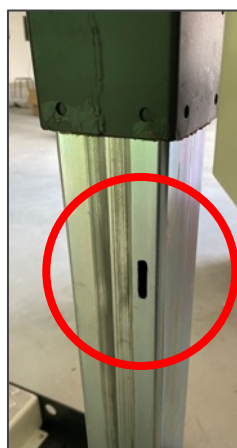

3. Insert the locking pin in the relevant slot in the column and slide it downwards until it locks, adhering to the column as shown in the picture and lock it with the previously removed knob;

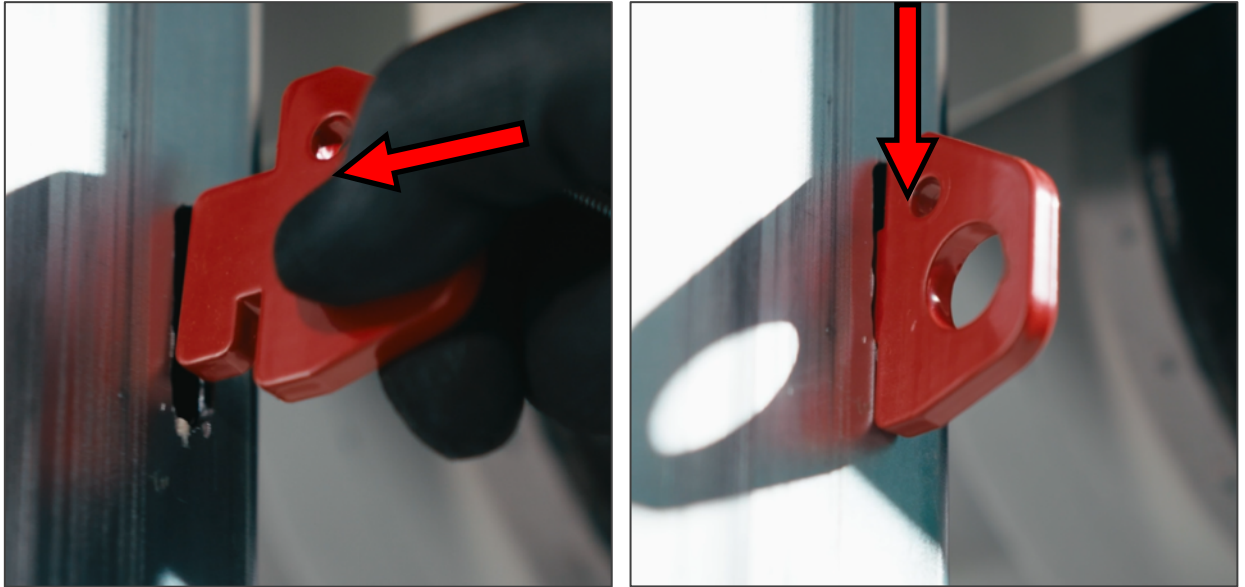

4. Move the cage down until it locks, using the emergency descent procedure described in the specific chapter "EMERGENCY OPERATION".
5. Retighten the emergency descent knurled knob.

When maintenance is over, to remove the locking pin, climb onto the cage using a ladder or suitable support, raise the cage a bit, get out of the cage and follow the previous instructions from point 3 in reverse order.

**BATTERY MAINTENANCE**

It is required to periodically check the terminals for any corrosion as well as for proper tightening. If required, replace the batteries as follows:

1. Make sure the machine is not connected to an external mains supply (charging batteries);
2. Use the specific switch to disconnect the machine's power supply;
3. Open the protective cover of the battery compartment;
4. Loosen the connection terminals of the batteries (positive pole and negative pole);
5. Remove the batteries and replace them with new ones;
6. Connect the terminals of the batteries, making sure to do so correctly (red wire for the positive pole, black wire for the negative pole) and tighten them;
7. Close and lock the protective cover.



**CAUTION**

**SHOULD THE BATTERY BE DAMAGED, USE THE APPROPRIATE PERSONAL PROTECTIVE EQUIPMENT TO PROTECT YOUR HANDS AGAINST CHEMICAL AGGRESSION WHEN REPLACING THE BATTERY.  
DISPOSE OF THE BATTERIES IN ACCORDANCE WITH THE LAWS IN FORCE.  
REPLACE THE BATTERIES WITH THE SAME TYPE AS SUPPLIED BY THE MANUFACTURER.**

**HYDRAULIC OIL CHANGE**

Faraone Industrie Spa recommends using hydraulic oil with viscosity index 32. It is strongly advised against mixing oils of different makes or types, since they may not contain the necessary additives or viscosity may be different.



**CAUTION**

**THE HYDRAULIC OIL MUST BE TOPPED UP/CHANGED WITH THE CAGE FULLY DOWN; IF THE HYDRAULIC OIL TANK IS UNDER THE CAGE, KEEP IT AT A HEIGHT OF APPROXIMATELY ONE METRE AND PERFORM TOPPING UP/CHANGE.**





**CAUTION**

**DISPOSE OF THE WASTE OIL IN ACCORDANCE WITH THE LAWS IN FORCE.**

**REPLACING THE TRACTION WHEELS (ELEVAH 40 MOVE PICKING)**

If required, replace the wheels as follows:

1. Remove the locking screws  ;  
Put the service screws in the appropriate extraction holes  and fasten them until they enter freely;
2. At the start of release, alternately tighten the screws, in order to undo the part of the wheel forced on the hub; then tap it a few times with a hammer to extract it completely.



**Reassembly**

1. Assemble the wheel and insert the locking screws;
2. Adjust the position of the wheel so that the screws and any reference pins can fit into their housings; if the motor is running to facilitate centring the holes, use 2 threaded bars screwed onto the crown gear;
3. Tighten with one turn at a time, alternately, until completely locked.

**NOTE:** it is advisable to replace the wheel before the thickness of the tread drops below 5 mm.

**TRANSMISSION MOTOR (ELEVAH 40 MOVE PICKING)**

**Checking the condition of the motor**

1. Unscrew the two M5 tie rods  and extract the aluminium cap complete with brush holder;
2. Use compressed air to eliminate carbon dust deposits on the inner surfaces of the motor.
3. With manifold motors, check the length of the brushes and their smooth movement in their housings.

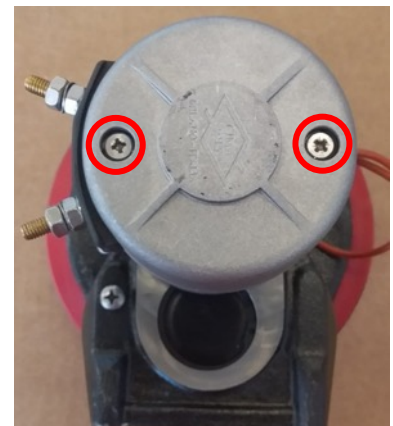

**Checking the brushes**

Check smooth movement as well as length of the brushes to ensure good performance.

Dimension	Maximum length	Minimum length
17 x 8	19 mm.	10.5 mm.

When replacing brushes, pay utmost attention to the welds.

**Checking the manifold**

If the surface of the manifold bears signs of burns, reduced diameter in relation to the brushes or eccentricity, repeat turning and dressing of the surface and undercutting between the slats. Extract the armature by first disassembling the electromagnetic brake mounted on the opposite side and then removing the armature itself, while being careful of any accidental impact caused by the flow of the magnets.



## Checking the bearings

Make sure that neither bearing is noisy and has no excessive backlash.

**NOTE:** whenever maintenance is performed, it is recommended to replace all consumables – considering these to also include the screws complete with washers and anti-loosening treatment, the keys and the corrugated washers.



**CAUTION**

**FOLLOWING A STRONG COLLISION, WE RECOMMEND THOROUGHLY CHECKING THE CASTING OF THE REDUCER, THE WHEEL, THE GEARS AND THE BEARINGS**

## ELECTROMAGNETIC BRAKE (ELEVAH 40 MOVE PICKING)

### Checking the electromagnet

The maximum braking torque of the electromagnetic brakes available is indicated below according to diameter:

∅ 80 Econ	C = 0.4 Kgm
∅ 80	C = 0.6 Kgm

### Checking the electromagnet

If the brake does not release and lock the lining properly when it is energised and de-energised in alternation, measure the resistance of the winding, which must be as follows:

	∅ 80 Econ	∅ 80
- 24 Volt brake	70 Ω	25 Ω

Also check the insulation towards the motor, using a 500-volt Megohmmeter to measure the insulation resistance, which must be above 0.1 MΩ.

The electromagnet must be replaced if it does not fulfil these conditions.

### Replacing the electromagnet and checking the lining with a splined hub

Remove any brake covers and completely loosen the three fixing screws and remove the electromagnet and check the lining disk.

Its thickness must be about 7 mm for the ∅80 mm type.

If the thickness is less than 5 mm, it is advisable to replace the complete lining of the splined hub after having removed the Seeger ring or self-locking nut.

Refit the new lining.

### Calibrating the clearance

Calibration should be carried out as described below when replacing the lining or the entire electromagnetic brake:

- loosen the three hexagonal adjustment bushes;
- adjust the three fixing screws so as to obtain a clearance between 0.2 and 0.4 mm;
- lock the three hexagonal adjustment bushes and check, with a thickness gauge, that the clearance is within the permitted limits.

**CHANGING THE TORQUE REDUCER GREASE (ELEVAH 40 MOVE PICKING)****CAUTION****PAY ATTENTION BECAUSE DURING NORMAL OPERATION THE SURFACES ARE HOT**

The body of the reducer contains a quantity of semi-fluid grease (AGIP GR MU/EP1 or equivalent) sufficient for over 1,000 hours of operation.

The grease must be changed during the general overhaul of the drive wheels.

**CAUTION****DISPOSE OF THE REPLACED GREASE IN ACCORDANCE WITH THE LAWS IN FORCE.****REPLACING THE EXTENSION SLIDING PADS**

Each part of the lifting column, called extension, slides over the other by means of nylon pads. With regular machine use, these pads could be worn and this could cause direct rubbing of the extensions, thereby compromising machine efficiency.

As soon as you begin noticing the extensions rubbing directly, it is **mandatory** to stop the machine and replace the pads.

For this, it is advisable to contact Faraone S.p.A. or an authorised maintenance centre.

The following procedure must be strictly complied with to replace the pads.

**Removing worn pads**

1. Lift the machine with a forklift and unscrew the fixing nut found under the machine that connects the cage unit to the hydraulic cylinder and reposition the machine on the ground;

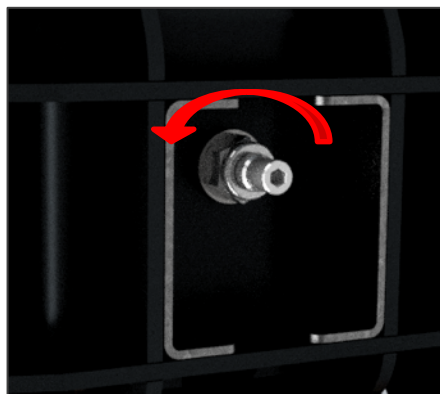

- Lift the cage unit using a winch or other lifting equipment, completely extracting the second extension (part of the cage unit) from the column and remove the eight pads (1) on it;

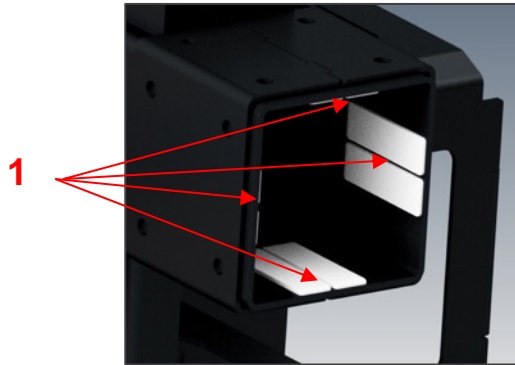

- Remove all the pads (2) present (2 on each side) in the upper part of the first extension that remain connected to the machine base;

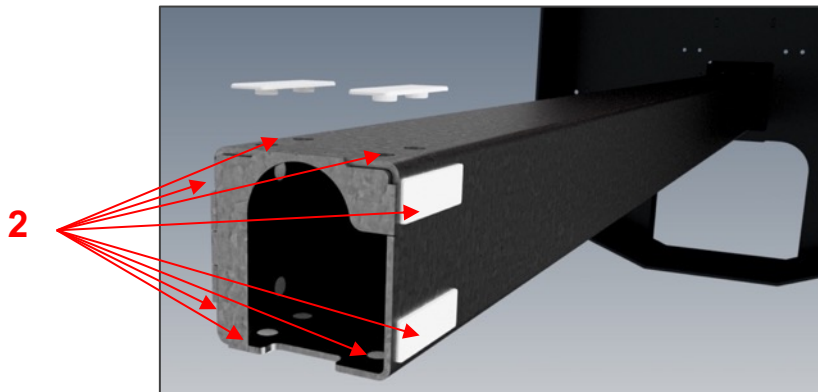

- Remove the old layer of grease and clean all the surfaces.

**Installing new pads**

- Grease the seats of the pads on the extensions;
- Insert two new pads, on each side, in the holes (1) made externally, at the top of the first extension that remains connected to the machine base;

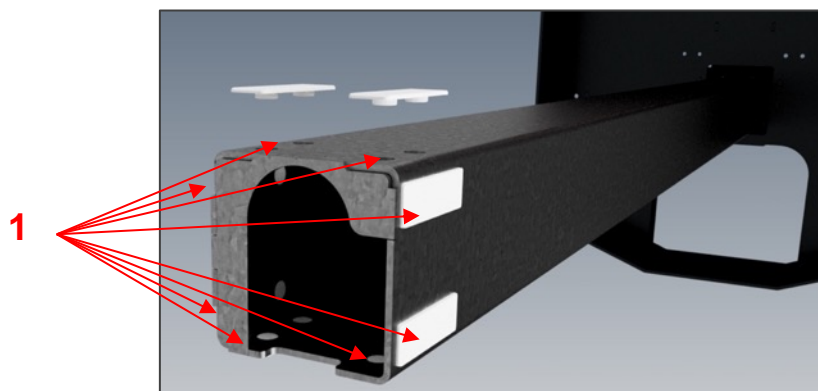

2. Insert the eight new pads (2 on each side) into the holes (2) made internally, at the base of the second extension (part of the cage unit) and insert it all the way into the first extension;

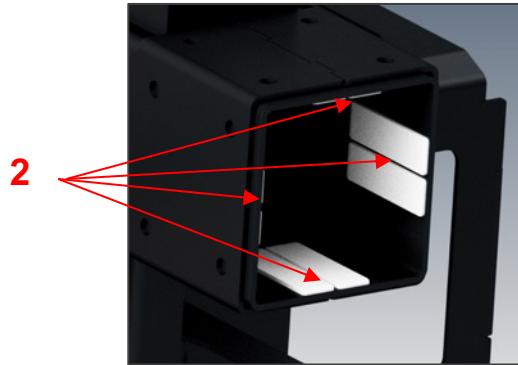

3. Lift the machine with a forklift and retighten the nut that connects the cage unit/last extension to the hydraulic cylinder and reposition the machine on the ground.

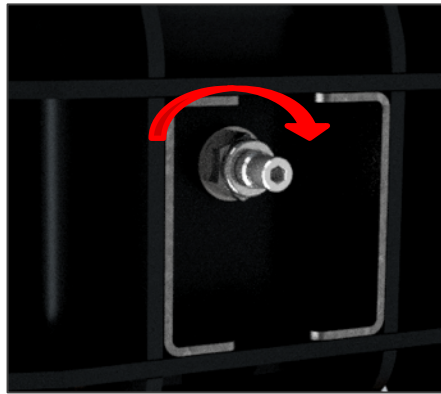

**CAUTION**

**GREASE/LUBRICATE THE LIFTING COLUMN ONLY WITH "MOLYKOTE G-4500 FM"  
GREASE OR PRODUCTS WITH THE SAME TECHNICAL CHARACTERISTICS.**



**CAUTION**

**FOR FURTHER INFORMATION REGARDING THE PURCHASE OF SPARE PARTS AND  
CONSUMABLES, PLEASE CONTACT THE MANUFACTURER.  
THE MANUFACTURER DISCLAIMS ALL LIABILITY FOR DAMAGE OR MALFUNCTION  
CAUSED BY USE OF PARTS NOT AUTHORISED BY THE MANUFACTURER**

**SECTION 9. ATTACHED DOCUMENTATION**









- ✓ ATTACHMENT 1 – Layout for decal application;
- ✓ ATTACHMENT 2 - Fluid power layout;
- ✓ ATTACHMENT 3 – Electrical layout ELEVVAH 40 MOVE PICKING;
- ✓ ATTACHMENT 4 – Electrical layout for ELEVVAH 40 B PICKING;
- ✓ ATTACHMENT 5 – Successful acceptance test certificate;
- ✓ ATTACHMENT 6 – Declaration of conformity.



**CAUTION**

**SHOULD THE MACHINE BE SOLD TO A THIRD PARTY, ALL DOCUMENTATION MUST BE DELIVERED WITH IT.**

**ATTACHMENT 1 – Layout for decal application**

Pos.	SYMBOL	DESCRIPTION	Pos.	SYMBOL	DESCRIPTION
1		<b><u>DANGER SIGN</u></b> RISK OF FALLING OBJECTS FROM ABOVE	2		<b><u>PROHIBITION SIGN</u></b> DO NOT REMOVE THE SAFETY GUARDS AND DEVICES
3		<b><u>PROHIBITION SIGN</u></b> UNAUTHORISED PERSONNEL MUST NOT USE THE MACHINERY	4		<b><u>OBLIGATION SIGN</u></b> REFER TO THE OPERATING MANUAL
5		<b><u>OBLIGATION SIGN</u></b> WEAR SAFETY SHOES	6	Max 200 kg 	<b><u>INDICATION</u></b> Maximum number of persons and load on the cage
7	<b><u>INDICATION</u></b>	“BATTERY CHARGING POSITION”	8	<b><u>INDICATION</u></b>	“RETAINING ONLY 1 PERSON”
9	<b><u>INDICATION</u></b>	“EMERGENCY DESCENT”	10	<b><u>INDICATION</u></b>	“EMERGENCY DESCENT PROCEDURE”
11		“GRIPPING POINT FOR MOVING THE MACHINE” (ELEVVAH 40 B)	12	<b><u>PLATE</u></b>	CE plate
13		<b><u>DANGER SIGN</u></b> CRUSHING AND TRAPPING OF UPPER LIMBS	14	<b><u>INDICATION</u></b>	“MAX 100 KG”

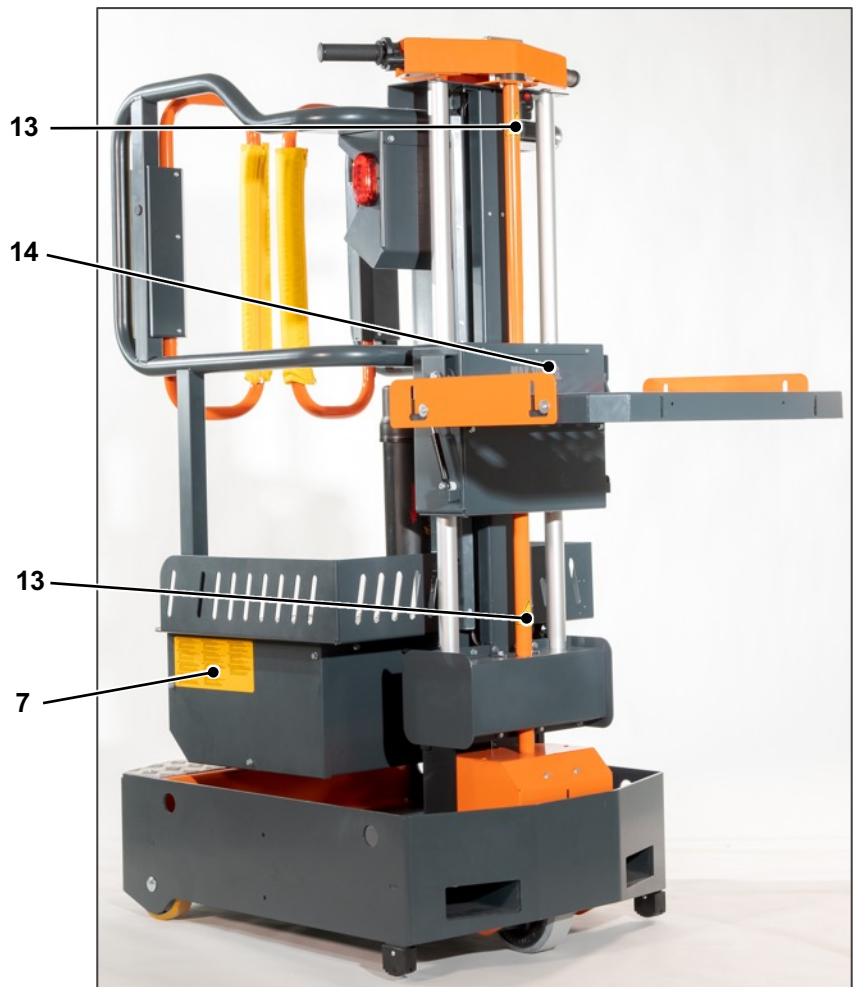
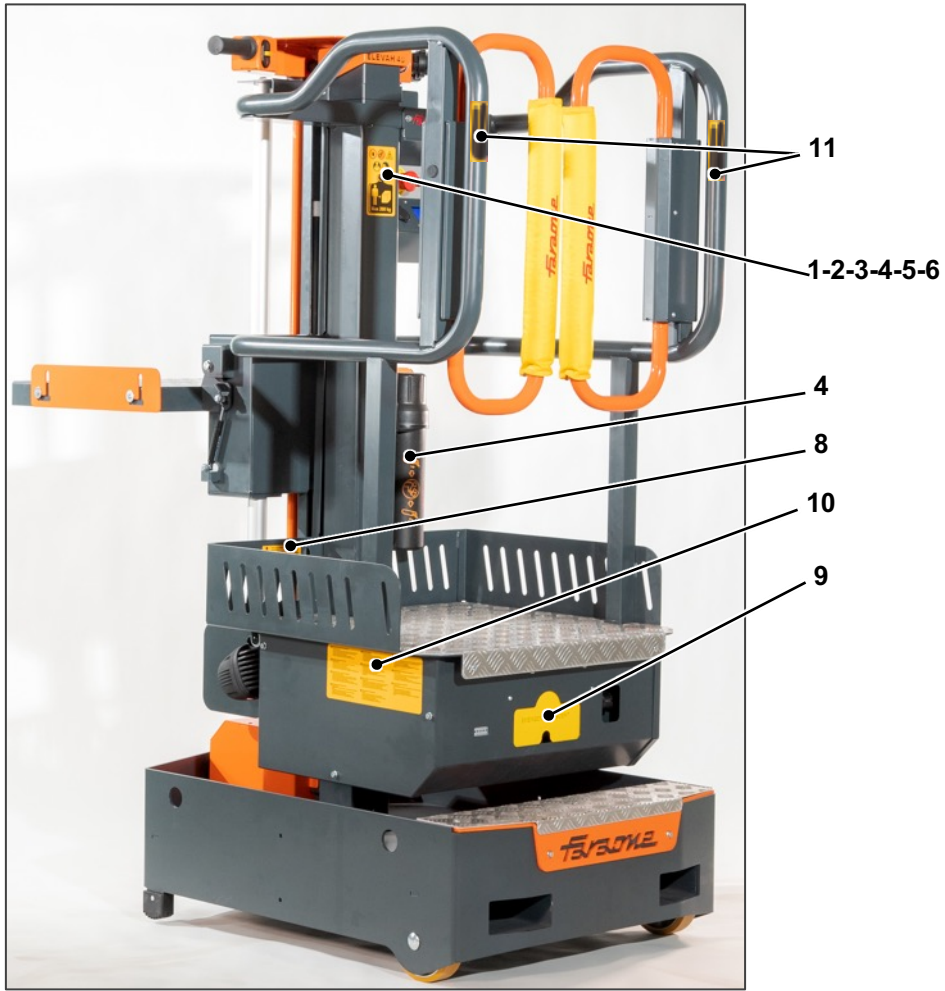



ATTACHMENT 2 - Hydraulic diagram

**NOTE DI MONTAGGIO**

Collaudo	2600 RPM
Taratura v. max	65 Bar su entrambe
Posiz. montaggio	Orizzontale, tappo lato blocco
Posiz. filtro	Lato fissaggi M10

**ATTENZIONE:** Bloccare pastiglia con loctite, posizionare appena in linea con il collettore, non avvitare fino in fondo

**ATTENZIONE:** Bloccare con locitite tipo A, verificare che non tocchi sul fondo del serbatoio

**ATTENZIONE:** Montare etichetta lato destro rispetto a blocco

**C1-C2-T-G1/4"**

Num. articolo	Num. parte	DENOMINAZIONE	Quantità
1	ES514026	Collettore PU05-M2R per gr.05rev+Dr	1
2	EC035M06	Tappo expander Ø6	2
3	EC114024	Anello O-Ring NBR 70Sh. 21.95x1.78 - 2087	1
4	EC114261	Anello O-Ring NBR 70Sh. 88.50x3.53 - 43.50	1
5	F73200253810D02	V.rit. VRF3/8 STØ10 doppio senza sfere	1
6	F73200138	Valvola ritegno VR38	2
7	F733014130	Valvola max VMCS 130 bar	2
8	EC10901_50007	Pompa Ø0R1_50X060	1
9	ES524AA 100	8D100-Tubo aspir.pl. 3/8" L=100	1
10	C185ABW38CF38	Raccordo 2458 90° 3/8" M-F	1
11	ES506FR_102319	Filtro in metallo G3/8F Ø63H18 101 90j FM02	1
12	ES5202100	Tubo di scarico fe. M10x1 L100	2
13	F012SPM03DC1	SPM03D-Serb plast quadri II 2,5 DIEST	1
14	C05609090110	Fascetta stringitubo H9 Ø90-110	1
15	ES507001	Flangia x FC11 [Id. Ø71 -> Ø63,5]	1
16	ES5085320021	Giunto (M-DC) 01.5-050-080	1
17	EC106203	Motore CC 24V-800W AME1705	1
18	ES462010100	Boccola premi molla 1/4" Ø1,00	1
19	F751167_35_140	Blocco MIR+T con n°2 overc. 1:4-100-350 bar + SRS, tar. 140 bar	1
20	EC031001	Tappo ICEI con OR. 1/4"	1
21	EC12601ST12	Tappo di protezione G1/4"-F	2

IND.	MODIFICA	DATA	NOTE
00	EMISSIONE	12/03/2021	D. Sacconi
01	REVISIONE	12/03/2021	D. Sacconi

DENOMINAZIONE  
104\_M2RXX/P010R/SPM03H/C203/FC11/1V/G00

TECFLUID S.p.A.  
Via Garibaldi 59, 38  
47024 Marzotto - Romagna - Italia  
Tel. 0521 932088 - Fax 0521 926401

ATTACHMENT 3 – Electrical layout - ELEVAH 40 MOVE PICKING

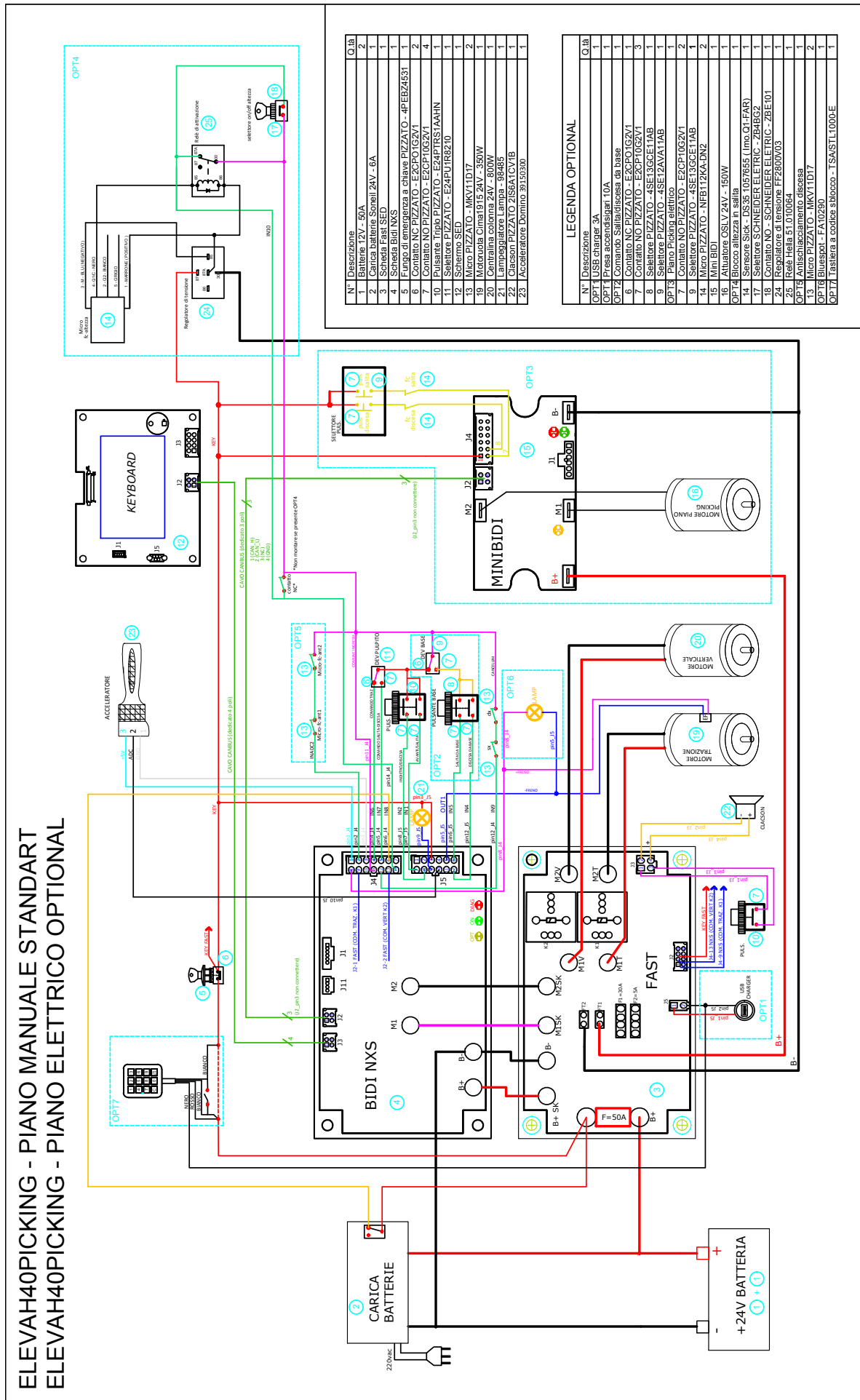



**ATTACHMENT 4 – Electrical layout - ELEVAH 40 B PICKING**

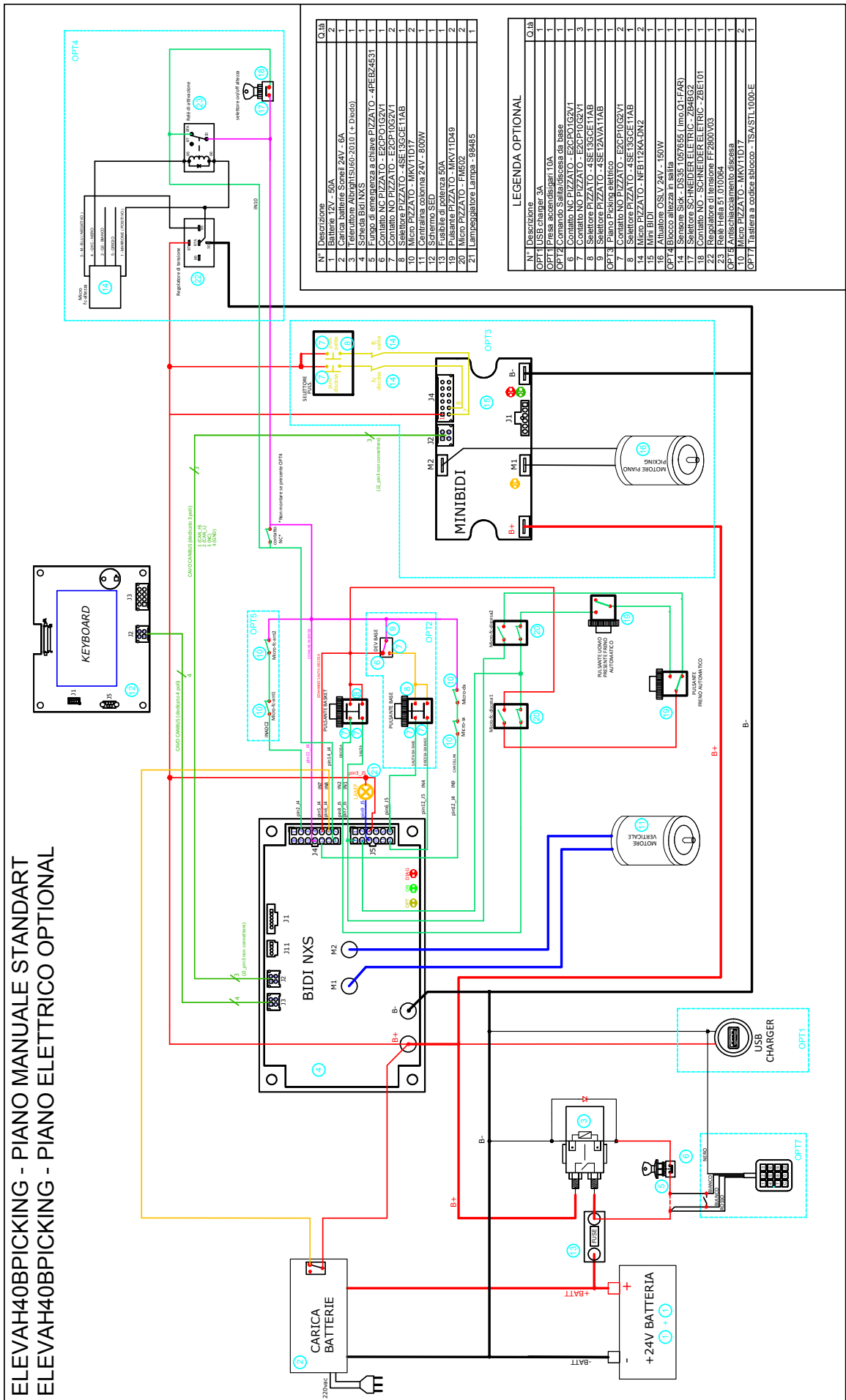

**ATTACHMENT 5 – Successful acceptance test certificate****STOCK PICKER**

- ELEVAH 40 MOVE PICKING
- ELEVAH 40 B PICKING

Serial number:

The machine has been subjected to the following tests:

- Static stability tests
- Overload test
- Operating test

And has PASSED them successfully.

Tortoreto, (date)

**ATTACHMENT 6 – Declaration of conformity**



**FARAONE INDUSTRIE SPA**  
Via San Giovanni, 20 - C.da Salino  
64018 Tortoreto (TE) ITALY  
Tel. +39 0861.772221  
Fax +39 0861.772222

[www.faraone.com](http://www.faraone.com)  
[info@faraone.com](mailto:info@faraone.com)  
REA 92848 CCIAA TE  
P.IVA e C.F. IT 00732060678  
C.S. euro 2.000.000 i.v.

**DICHIARAZIONE DI CONFORMITA' - DECLARATION OF CONFORMITY  
DECLARATION DE CONFORMITE' – EG KONFORMITÄTSEKTLÄRUNG**



Macchina/Machine/Machine/Maschine	<b>Carrello Commissionatore/Stock Picker/Chariot commissionateur/Kommissioniergerät</b>
Modello/Model/Modèle/Modell	<b>XXXXXXXXXXXX</b>
Matricola/Serial No./Numéro sérial/Laufende Nr.	<b>XXXX/XXXX</b>
Anno/Year/Année/Jahr	<b>XXXX</b>
No. certificato/Technical Report of Compliance Nr. / Rapport technique de conformité No. /Zeugnis Nr.	<b>XXXXXXXXXXXXXXXXXXXX</b>

Il sottoscritto Faraone Pier Giuseppe, in qualità di legale rappresentante della ditta FARAONE INDUSTRIE S.p.A. – C.da Salino, Tortoreto (Italia), Costruttore, nonché persona giuridica autorizzata a costituire il fascicolo tecnico per la macchina in oggetto DICHIARA CHE il carrello commissionatore summenzionato è stata fabbricata conformemente ai requisiti di sicurezza e salute previsti dalla Direttiva Macchine 2006/42/CE ed alla norma armonizzata UNI EN 3691-1:2020 ed al modello verificato da: TUV ITALIA S.r.l. – TUV SUD Group, Via G. Carducci, 125 pal 23 – 20099 Sesto S. Giovanni (MI) Italy.

Il Fascicolo Tecnico di costruzione è conservato presso la FARAONE INDUSTRIE S.p.A.

Il Fascicolo Tecnico e la versione originale delle istruzioni di uso e manutenzione vengono redatti in lingua italiana.

The undersigned Faraone Pier Giuseppe, as legal representative of the company FARAONE INDUSTRIE S.p.A. – C.da Salino, Tortoreto (Italy), manufacturer, as well as a legal person authorized to compile the technical file for the machine in question, DECLARES THAT, the stock picker mentioned above has been manufactured in accordance with the requirements of safety and health of the Machine Directive 2006/42/CE and harmonized standard UNI EN 3691-1:2020 and model checked by TUV ITALIA S.r.l. – TUV SUD Group, Via G. Carducci, 125 pal 23 – 20099 Sesto S. Giovanni (MI) Italy.

The technical reference of the platform are kept in the records of FARAONE INDUSTRIE S.p.A.

The technical file and the original version of the user's manual are written in Italian.

Le soussigné Faraone Pier Giuseppe, agissant en tant que représentant légal de la société FARAONE INDUSTRIE S.p.A. – C. da Salino, Tortoreto (Italie), fabricant, ainsi qu'une personne morale autorisée à constituer le dossier technique de la machine en question DECLARE QUE, le chariot commissionateur susmentionnée a été fabriqué en conformité avec les critères de sécurité et de la santé de la Directive Machines 2006/42/CE et la norme harmonisée UNI EN 3691-1:2020 et le modèle certifié par TUV ITALIA S.r.l. – TUV SUD Group, Via G. Carducci, 125 pal 23 – 20099 Sesto S. Giovanni (MI) Italy.

Le dossier technique de construction est entreposé chez FARAONE INDUSTRIE S.p.A.

Le dossier technique et la version originale des instructions de fonctionnement et d'entretien sont écrits en italien.

Der unterzeichnete Faraone Pier Giuseppe, als gesetzlicher Vertreter der Firma FARAONE INDUSTRIE S.p.A. – C.da Salino, Tortoreto (Italien), sowie Hersteller und Person die bevollmächtigt ist die technischen Unterlagen für die o.g. Maschine zusammenzustellen, ERKLÄRT dass das o.g. Kommissioniergerät nach den Sicherheits- und Gesundheitsanforderungen der Maschinenrichtlinie 2006/42/EG und der harmonisierten UNI EN 3691-1:2020 gefertigt wurde. Die Maschine ist mit dem Modell identisch welches von TUV ITALIA S.r.l. – TUV SUD Group, Via G. Carducci, 125 pal 23 – 20099 Sesto S. Giovanni (MI) Italy, geprüft wurde.

Die technischen Bauunterlagen werden bei FARAONE INDUSTRIE S.p.A. aufbewahren.

Die technischen Unterlagen und die ursprüngliche Version der Bedienungs- und Wartungsanleitungen sind in Italienisch geschrieben.

Tortoreto, XX/XX/XXXX

Il Legale Rappresentante  
(Faraone Pier Giuseppe)

**FARAONE**  
Industrie spa  
C.da Salino - Via San Giovanni, 20  
64018 TORTORETO (Te) - Tel. 0861.772221  
Fax 0861.772222 - R. IVA 00732060678



**SECTION 10. MAINTENANCE LOGBOOK**

**MAINTENANCE**

OPERATOR: \_\_\_\_\_

DATE: \_\_\_\_\_

**Six monthly** (can be carried out by the operator)

	DONE	
	✓	x
Check correct operation of the emergency descent valve		
Check the hydraulic oil level		
Check the hydraulic oil pipes and make sure there are no leaks		
Check the cage and entrance doors		
Check the correct operation and integrity of the controls		

**Yearly** (must be carried out by adequately trained personnel)

Perform "SIX-MONTHLY MAINTENANCE"		
Check the column sliding pads		
Transmission motor: Check the brushes and manifold for wear.		
Check there is no clearance, mechanical parts not correctly secured and/or bent and no damaged welds on parts/components		
Check the integrity of the structural profiles		
Check the wheels for wear		

**Biennial** (must be carried out by adequately trained personnel)

Perform "SIX-MONTHLY AND ANNUAL MAINTENANCE"		
Hydraulic oil change		
Torque Reducer: Inspection and oil change		
Transmission motor: Carry out a general overhaul of the drive wheels.		

Date: \_\_\_\_\_

Signature: \_\_\_\_\_

NOTES

**MAINTENANCE**

OPERATOR: \_\_\_\_\_

DATE: \_\_\_\_\_

**Six monthly** (can be carried out by the operator)

	DONE	
	✓	✗
Check correct operation of the emergency descent valve		
Check the hydraulic oil level		
Check the hydraulic oil pipes and make sure there are no leaks		
Check the cage and entrance doors		
Check the correct operation and integrity of the controls		

**Yearly** (must be carried out by adequately trained personnel)

Perform "SIX-MONTHLY MAINTENANCE"		
Check the column sliding pads		
Transmission motor: Check the brushes and manifold for wear.		
Check there is no clearance, mechanical parts not correctly secured and/or bent and no damaged welds on parts/components		
Check the integrity of the structural profiles		
Check the wheels for wear		

**Biennial** (must be carried out by adequately trained personnel)

Perform "SIX-MONTHLY AND ANNUAL MAINTENANCE"		
Hydraulic oil change		
Torque Reducer: Inspection and oil change		
Transmission motor: Carry out a general overhaul of the drive wheels.		

Date: \_\_\_\_\_

Signature: \_\_\_\_\_

<p>NOTES</p>
--------------

**MAINTENANCE**

OPERATOR: \_\_\_\_\_

DATE: \_\_\_\_\_

	DONE	
	✓	✗
<b>Six monthly</b> (can be carried out by the operator)		
Check correct operation of the emergency descent valve		
Check the hydraulic oil level		
Check the hydraulic oil pipes and make sure there are no leaks		
Check the cage and entrance doors		
Check the correct operation and integrity of the controls		

**Yearly** (must be carried out by adequately trained personnel)

Perform "SIX-MONTHLY MAINTENANCE"		
Check the column sliding pads		
Transmission motor: Check the brushes and manifold for wear.		
Check there is no clearance, mechanical parts not correctly secured and/or bent and no damaged welds on parts/components		
Check the integrity of the structural profiles		
Check the wheels for wear		

**Biennial** (must be carried out by adequately trained personnel)

Perform "SIX-MONTHLY AND ANNUAL MAINTENANCE"		
Hydraulic oil change		
Torque Reducer: Inspection and oil change		
Transmission motor: Carry out a general overhaul of the drive wheels.		

Date: \_\_\_\_\_

Signature: \_\_\_\_\_

<p>NOTES</p>
--------------

**MAINTENANCE**

OPERATOR: \_\_\_\_\_

DATE: \_\_\_\_\_

**Six monthly** (can be carried out by the operator)

	DONE	
	✓	✗
Check correct operation of the emergency descent valve		
Check the hydraulic oil level		
Check the hydraulic oil pipes and make sure there are no leaks		
Check the cage and entrance doors		
Check the correct operation and integrity of the controls		

**Yearly** (must be carried out by adequately trained personnel)

Perform "SIX-MONTHLY MAINTENANCE"		
Check the column sliding pads		
Transmission motor: Check the brushes and manifold for wear.		
Check there is no clearance, mechanical parts not correctly secured and/or bent and no damaged welds on parts/components		
Check the integrity of the structural profiles		
Check the wheels for wear		

**Biennial** (must be carried out by adequately trained personnel)

Perform "SIX-MONTHLY AND ANNUAL MAINTENANCE"		
Hydraulic oil change		
Torque Reducer: Inspection and oil change		
Transmission motor: Carry out a general overhaul of the drive wheels.		

Date: \_\_\_\_\_

Signature: \_\_\_\_\_

NOTES



**MAINTENANCE**

OPERATOR: \_\_\_\_\_

DATE: \_\_\_\_\_

	DONE	
	✓	✗
<b>Six monthly</b> (can be carried out by the operator)		
Check correct operation of the emergency descent valve		
Check the hydraulic oil level		
Check the hydraulic oil pipes and make sure there are no leaks		
Check the cage and entrance doors		
Check the correct operation and integrity of the controls		

**Yearly** (must be carried out by adequately trained personnel)

Perform "SIX-MONTHLY MAINTENANCE"		
Check the column sliding pads		
Transmission motor: Check the brushes and manifold for wear.		
Check there is no clearance, mechanical parts not correctly secured and/or bent and no damaged welds on parts/components		
Check the integrity of the structural profiles		
Check the wheels for wear		

**Biennial** (must be carried out by adequately trained personnel)

Perform "SIX-MONTHLY AND ANNUAL MAINTENANCE"		
Hydraulic oil change		
Torque Reducer: Inspection and oil change		
Transmission motor: Carry out a general overhaul of the drive wheels.		

Date: \_\_\_\_\_

Signature: \_\_\_\_\_

NOTES

**MAINTENANCE**

OPERATOR: \_\_\_\_\_

DATE: \_\_\_\_\_

**Six monthly** (can be carried out by the operator)

	DONE	
	✓	✗
Check correct operation of the emergency descent valve		
Check the hydraulic oil level		
Check the hydraulic oil pipes and make sure there are no leaks		
Check the cage and entrance doors		
Check the correct operation and integrity of the controls		

**Yearly** (must be carried out by adequately trained personnel)

Perform "SIX-MONTHLY MAINTENANCE"		
Check the column sliding pads		
Transmission motor: Check the brushes and manifold for wear.		
Check there is no clearance, mechanical parts not correctly secured and/or bent and no damaged welds on parts/components		
Check the integrity of the structural profiles		
Check the wheels for wear		

**Biennial** (must be carried out by adequately trained personnel)

Perform "SIX-MONTHLY AND ANNUAL MAINTENANCE"		
Hydraulic oil change		
Torque Reducer: Inspection and oil change		
Transmission motor: Carry out a general overhaul of the drive wheels.		

Date: \_\_\_\_\_

Signature: \_\_\_\_\_

NOTES

**MAINTENANCE**

OPERATOR: \_\_\_\_\_

DATE: \_\_\_\_\_

**Six monthly** (can be carried out by the operator)

	DONE	
	✓	✗
Check correct operation of the emergency descent valve		
Check the hydraulic oil level		
Check the hydraulic oil pipes and make sure there are no leaks		
Check the cage and entrance doors		
Check the correct operation and integrity of the controls		

**Yearly** (must be carried out by adequately trained personnel)

Perform "SIX-MONTHLY MAINTENANCE"		
Check the column sliding pads		
Transmission motor: Check the brushes and manifold for wear.		
Check there is no clearance, mechanical parts not correctly secured and/or bent and no damaged welds on parts/components		
Check the integrity of the structural profiles		
Check the wheels for wear		

**Biennial** (must be carried out by adequately trained personnel)

Perform "SIX-MONTHLY AND ANNUAL MAINTENANCE"		
Hydraulic oil change		
Torque Reducer: Inspection and oil change		
Transmission motor: Carry out a general overhaul of the drive wheels.		

Date: \_\_\_\_\_

Signature: \_\_\_\_\_

NOTES

**MAINTENANCE**

OPERATOR: \_\_\_\_\_

DATE: \_\_\_\_\_

**Six monthly** (can be carried out by the operator)

	DONE	
	✓	✗
Check correct operation of the emergency descent valve		
Check the hydraulic oil level		
Check the hydraulic oil pipes and make sure there are no leaks		
Check the cage and entrance doors		
Check the correct operation and integrity of the controls		

**Yearly** (must be carried out by adequately trained personnel)

Perform "SIX-MONTHLY MAINTENANCE"		
Check the column sliding pads		
Transmission motor: Check the brushes and manifold for wear.		
Check there is no clearance, mechanical parts not correctly secured and/or bent and no damaged welds on parts/components		
Check the integrity of the structural profiles		
Check the wheels for wear		

**Biennial** (must be carried out by adequately trained personnel)

Perform "SIX-MONTHLY AND ANNUAL MAINTENANCE"		
Hydraulic oil change		
Torque Reducer: Inspection and oil change		
Transmission motor: Carry out a general overhaul of the drive wheels.		

Date: \_\_\_\_\_

Signature: \_\_\_\_\_

NOTES

### MAINTENANCE

OPERATOR: \_\_\_\_\_

DATE: \_\_\_\_\_

**Six monthly** (can be carried out by the operator)

	DONE	
	✓	x
Check correct operation of the emergency descent valve		
Check the hydraulic oil level		
Check the hydraulic oil pipes and make sure there are no leaks		
Check the cage and entrance doors		
Check the correct operation and integrity of the controls		

**Yearly** (must be carried out by adequately trained personnel)

Perform "SIX-MONTHLY MAINTENANCE"		
Check the column sliding pads		
Transmission motor: Check the brushes and manifold for wear.		
Check there is no clearance, mechanical parts not correctly secured and/or bent and no damaged welds on parts/components		
Check the integrity of the structural profiles		
Check the wheels for wear		

**Biennial** (must be carried out by adequately trained personnel)

Perform "SIX-MONTHLY AND ANNUAL MAINTENANCE"		
Hydraulic oil change		
Torque Reducer: Inspection and oil change		
Transmission motor: Carry out a general overhaul of the drive wheels.		

Date: \_\_\_\_\_

Signature: \_\_\_\_\_

NOTES

**MAINTENANCE**

OPERATOR: \_\_\_\_\_

DATE: \_\_\_\_\_

**Six monthly** (can be carried out by the operator)

	DONE	
	✓	✗
Check correct operation of the emergency descent valve		
Check the hydraulic oil level		
Check the hydraulic oil pipes and make sure there are no leaks		
Check the cage and entrance doors		
Check the correct operation and integrity of the controls		

**Yearly** (must be carried out by adequately trained personnel)

Perform "SIX-MONTHLY MAINTENANCE"		
Check the column sliding pads		
Transmission motor: Check the brushes and manifold for wear.		
Check there is no clearance, mechanical parts not correctly secured and/or bent and no damaged welds on parts/components		
Check the integrity of the structural profiles		
Check the wheels for wear		

**Biennial** (must be carried out by adequately trained personnel)

Perform "SIX-MONTHLY AND ANNUAL MAINTENANCE"		
Hydraulic oil change		
Torque Reducer: Inspection and oil change		
Transmission motor: Carry out a general overhaul of the drive wheels.		

Date: \_\_\_\_\_

Signature: \_\_\_\_\_

NOTES







Faraone Industrie Spa  
Contrada Salino – Via San Giovanni, 20  
64018, Tortoreto (TE) – ITALY  
Tel.: +39.0861.77.22.21 – fax: +39.0861.77.22.22  
[www.faraone.com](http://www.faraone.com)  
[info@faraone.com](mailto:info@faraone.com)